

30 INCH DIAMETER  
MINIMUM FOR SIZE ONLY.  
VOLUME MAY REQUIRE  
LARGER BASIN.

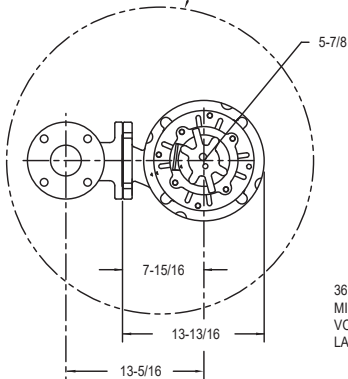

SIMPLEX INSTALLATION

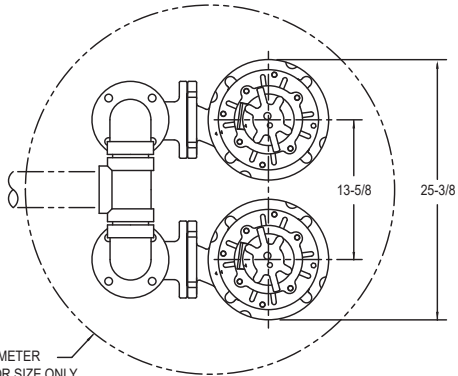

36 INCH DIAMETER  
MINIMUM FOR SIZE ONLY.  
VOLUME MAY REQUIRE  
LARGER BASIN.

DUPLEX INSTALLATION

DIMENSIONS BASED ON STANDARD ANSI FITTING SIZES  
CHECK VALVES REQUIRED, NOT SHOWN FOR CLARITY  
ALL DIMENSIONS IN INCHES UNLESS OTHERWISE NOTED

