

36 INCH DIAMETER
MINIMUM FOR SIZE ONLY.
VOLUME MAY REQUIRE
LARGER BASINS.

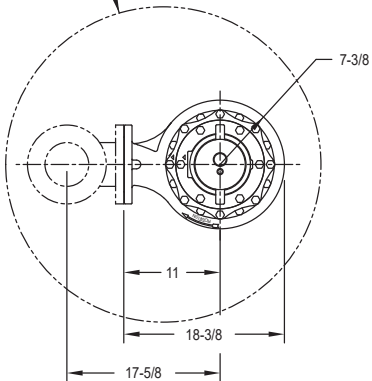

SIMPLEX INSTALLATION

48 INCH DIAMETER
MINIMUM FOR SIZE ONLY.
VOLUME MAY REQUIRE
LARGER BASINS.

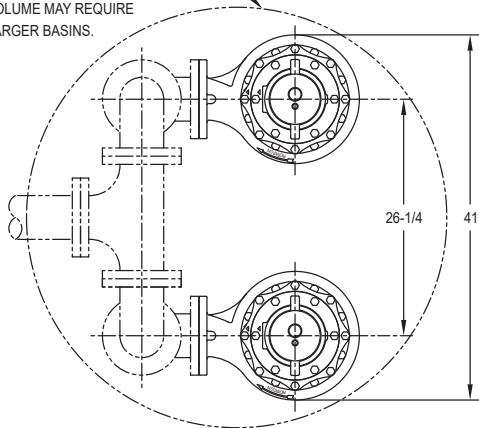

DUPLEX INSTALLATION

DIMENSIONS BASED ON STD. ANSI FITTING SIZES
CHECK VALVES REQUIRED, NOT SHOWN FOR CLARITY

4 GAGE	ø1.350
8 GAGE	ø.930
12 GAGE	ø.640

