

SIMPLEX INSTALLATION

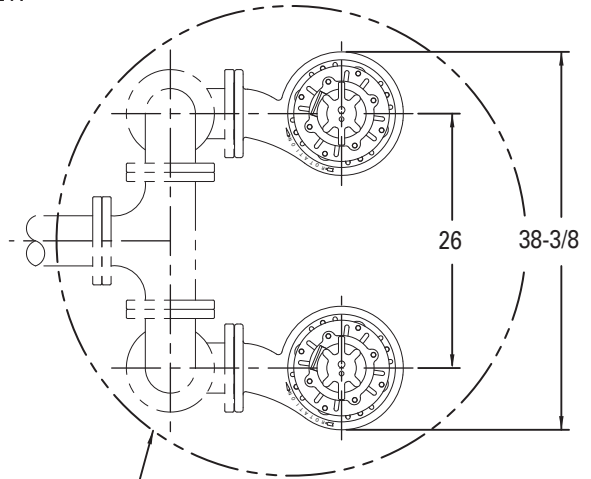

DUPLEX INSTALLATION

48 INCH DIAMETER
MINIMUM FOR SIZE ONLY.
VOLUME MAY REQUIRE
LARGER BASIN.

DIMENSIONS BASED ON STD. ANSI FITTING SIZES
CHECK VALVES REQUIRED, NOT SHOWN FOR CLARITY
ALL DIMENSIONS IN INCHES UNLESS OTHERWISE NOTED

FLA	DIAMETER
<20	.68
>20	.96

