

MAIL TO: P.O. BOX 16347 • Louisville, KY 40256-0347
 SHIP TO: 3649 Cane Run Road • Louisville, KY 40211-1961
 Tel: (502) 778-2731 • 1 (800) 928-PUMP

Visit our website:
zoellerengineered.com

Covered by US Patent Number 6,364,620.

Product information presented here reflects conditions at time of publication. Consult factory regarding discrepancies or inconsistencies.



62 HD SERIES

PRODUCT FEATURES

4" & 6" FLANGED DISCHARGE UNITS

Models: 6220 6221 6222 6223 6224

APPLICATIONS

- Engineered Lift Stations
- Storm Water Removal
- Wastewater Transfer
- Industrial Wastewater



SPECIFICATIONS PUMP:

- Solids - 3" spherical capability
- Discharge Size - 4" & 6" horizontal flanged
- Seals - dual mechanical silicon carbide / silicon carbide lower and carbon ceramic upper, Buna-N elastomers.
- Construction - Cast Iron ASTM A-48, Class 30, 30,000# tensile strength, corrosion resistant powder coated epoxy finish
- Attaching Hardware - 304 stainless steel
- O-ring Elastomers - Buna-N
- Impeller - 2 blade semi-open Ductile Iron with top pump out vanes
- Moisture detection system
- Optional:
 - Silicon Carbide Seal
 - Viton O-ring Elastomers
 - Vortex Impeller
 - Trimmed Impeller
 - Additional Cord Length _____
 - Dry Pit Configuration (5-10 BHP, not CSA listed)
 - High Temperature Construction (5-10 BHP, not CSA listed)
 - Inverter Duty Motors (cCSAus certified for VPWM type Inverter - 30 Hz to 60 Hz max.)
 - Rail Systems

MOTOR:

- 1 Phase - 230 Volt, 1750 RPM (5 and 7.5 BHP)
- 3 Phase - 200/230/460/575 Volt, 1750 RPM
- 5 thru 20 BHP
- Stator - Class F insulation and lead wires NEMA B design
- Thermal sensor and leads.
- Housing - Class 30 cast iron, finned, oil-filled
- Ball Bearings - Dual high carbon chromium steel
- Power Cable Length - 25'

FEATURES

1. 25' of extra heavy duty power cable
2. Protected cable entrance. The compression grommet allows for field replacement of the cable. Optional: 3" heavy wall conduit threads for protection of cable assemblies.
3. Potted cords. Each conductor individually sealed to eliminate cord wicking of liquids.
4. Lifting lugs integral part of housing (not shown)
5. Oil-filled motor housing with finned casting assures uniform heat distribution, lubricates bearings, and conducts heat for cooler running.
6. Heavy duty motor features ball bearing construction. Class F motor insulation is double dipped and baked. End connections and lead wires are Class F. At maximum load, winding temperature will not exceed 250 °F with motor housing not submerged.
7. Tandem seals, silicon carbide / silicon carbide lower and carbon ceramic upper, Buna-N elastomers.
8. Upper and lower high carbon chromium steel ball bearings
9. Stainless steel shaft and hardware resists corrosion
10. Patented moisture detection system with upper and lower probes, protecting the motor from liquid entry.

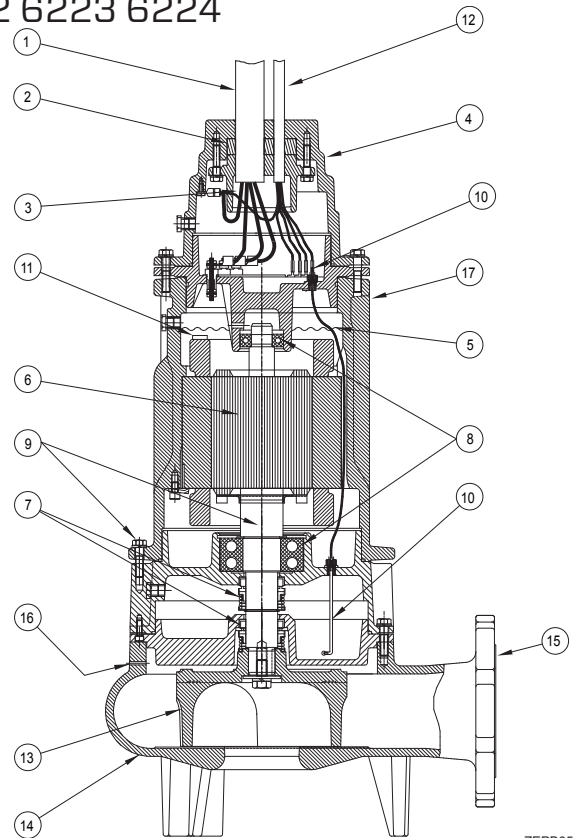

ZEPB0578

11. Thermal sensor provides protection against overheating
 12. 25' sensor cable
 13. Balanced 2 vane semi-open impeller with top pump out vanes for seal protection keyed and bolted to shaft. Recessed vortex design also available as an option.
 14. Concentric case reduces radial loading for longer bearing and seal life
 15. 4" or 6" flanged horizontal discharge. Dry pit units available upon request.
 16. Vent hole helps prevent air locking.
 17. Entire unit protected with a corrosion resistant powder coated epoxy finish
- For additional information on the 62 HD Series pumps, refer to catalog on Performance information, ZM2348 and ZM2349; Dimensional Data information, ZM2311, ZM2312, ZM2313 and ZM2314; Guide Specifications, ZM2350; Replacement Parts List and Repair Manual, ZM2354 and Owner's Manual, ZM2353.

For information on additional Zoeller products refer to catalog on Rail Systems, ZM1347; Control Panels, ZM1342; Float Switches and Bracket, ZM1328; J-Boxes, ZM1536; Pump Lifting Cables ZM1347, Check Valves and Piping Accessories, ZM1348.