

NOTICE TO INSTALLER: Instructions must remain with installation.

Trusted. Tested. Tough.®

Product information presented here reflects conditions at time of publication. Consult factory regarding discrepancies or inconsistencies.



ZM3321
0622
Supersedes
NEW

MAIL TO: P.O. BOX 16347 • Louisville, KY 40256-0347
SHIP TO: 3649 Cane Run Road • Louisville, KY 40211-1961
(502) 778-2731 • 1 (800) 928-PUMP • FAX (502) 774-3624

Visit our website:
zoellerengineered.com



REPAIR MANUAL

72 HD SERIES HEAVY DUTY SOLIDS HANDLING PUMPS

For over eighty years the name Zoeller has represented the standard for submersible dewatering and sewage pumps. The same high quality workmanship and easy maintenance design has been incorporated into this line of heavy-duty solids-handling submersible sewage pumps.

This manual incorporates the parts list and repair instructions into one document to aid in the ownership of a Zoeller submersible non-clog wastewater product. Please read and review this manual

before repairing the product. Follow the steps and procedures listed on ZM1074 for a proper start-up upon installation. Many items contained within, when followed correctly, will not only ensure a long and problem-free life for the pump, but also save time and money during installation. Reference ZM3320 for owner's manual on 72 HD Series Pumps. Should further assistance be necessary please call our Technical Service Department at 1-800-928-PUMP (7867).

Table of Contents

Safety Instructions	1
Replacement Parts List	2-3
Disassembly Procedures	4
Assembly Procedures.....	5-6
Pump Wiring Diagrams	7
Service Checklist	8

To Order Replacement Parts

PLEASE FURNISH THE FOLLOWING INFORMATION:

- Model Number
- Part Number of Pump
- Serial Number
- System Voltage
- Replacement Part Number and Description (refer to pages 2 & 3).

Short Term Storage

Storage of six months or less will not damage the submersible pump. However, to ensure the best possible protection, the following is advised:

- Store pump inside whenever possible or cover with some type of protective covering.
- Tape or seal in plastic bag the terminal ends of wire leads.
- Spray coat unpainted surfaces with rust-inhibiting oil.
- See ZM3320 Owner's Manual before start-up.

Safety Instructions

TO AVOID SERIOUS OR FATAL PERSONAL INJURY OR MAJOR PROPERTY DAMAGE, READ AND FOLLOW ALL SAFETY INSTRUCTIONS IN THIS MANUAL AND ON THE PUMP.

THIS MANUAL IS INTENDED TO ASSIST IN THE INSTALLATION AND OPERATION OF THIS UNIT AND MUST BE KEPT WITH THE PUMP.



This is a **SAFETY ALERT SYMBOL**.

When you see this symbol on the pump or in the manual, look for one of the following signal words and be alert to the potential for personal injury or property damage.

▲ DANGER Warns of hazards that **WILL** cause serious personal injury, death or major property damage.

▲ WARNING Warns of hazards that **CAN** cause serious personal injury, death or major property damage.

▲ CAUTION Warns of hazards that **CAN** cause personal injury or property damage.

▲ NOTICE INDICATES SPECIAL INSTRUCTIONS WHICH ARE VERY IMPORTANT AND MUST BE FOLLOWED.

THOROUGHLY REVIEW ALL INSTRUCTIONS AND WARNINGS PRIOR TO PERFORMING ANY WORK ON THIS PUMP.

MAINTAIN ALL SAFETY DECALS.

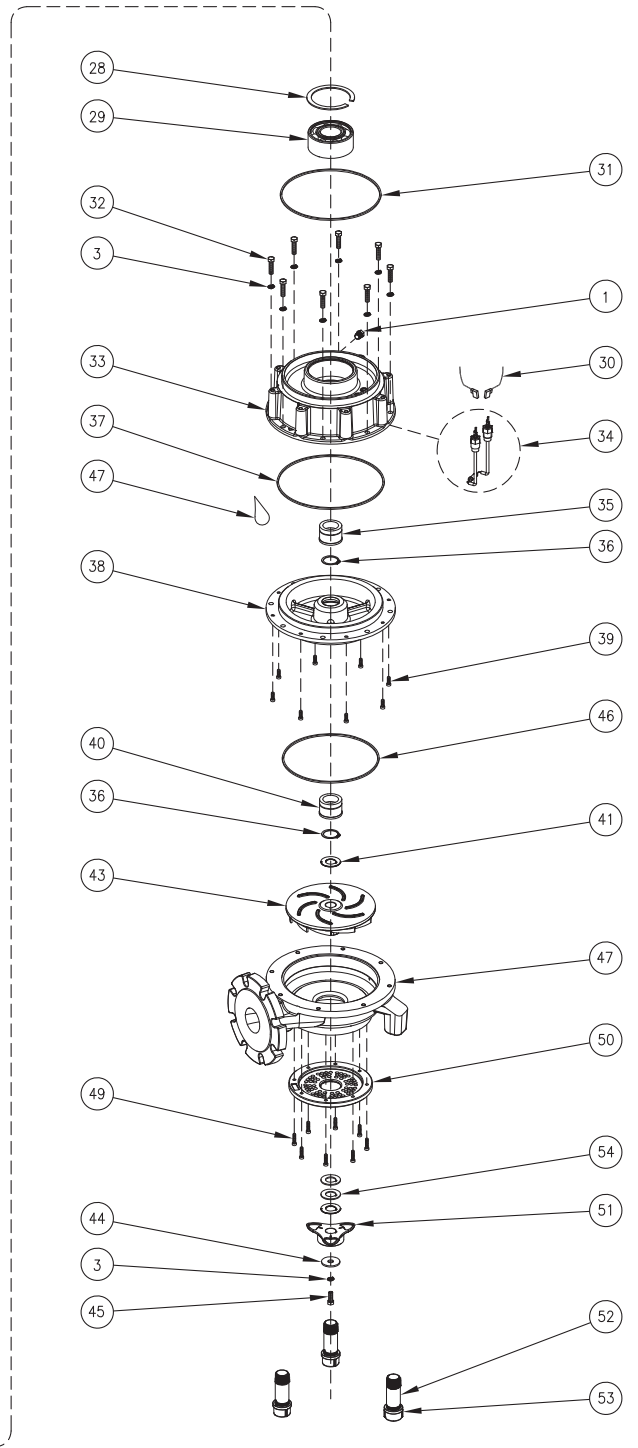
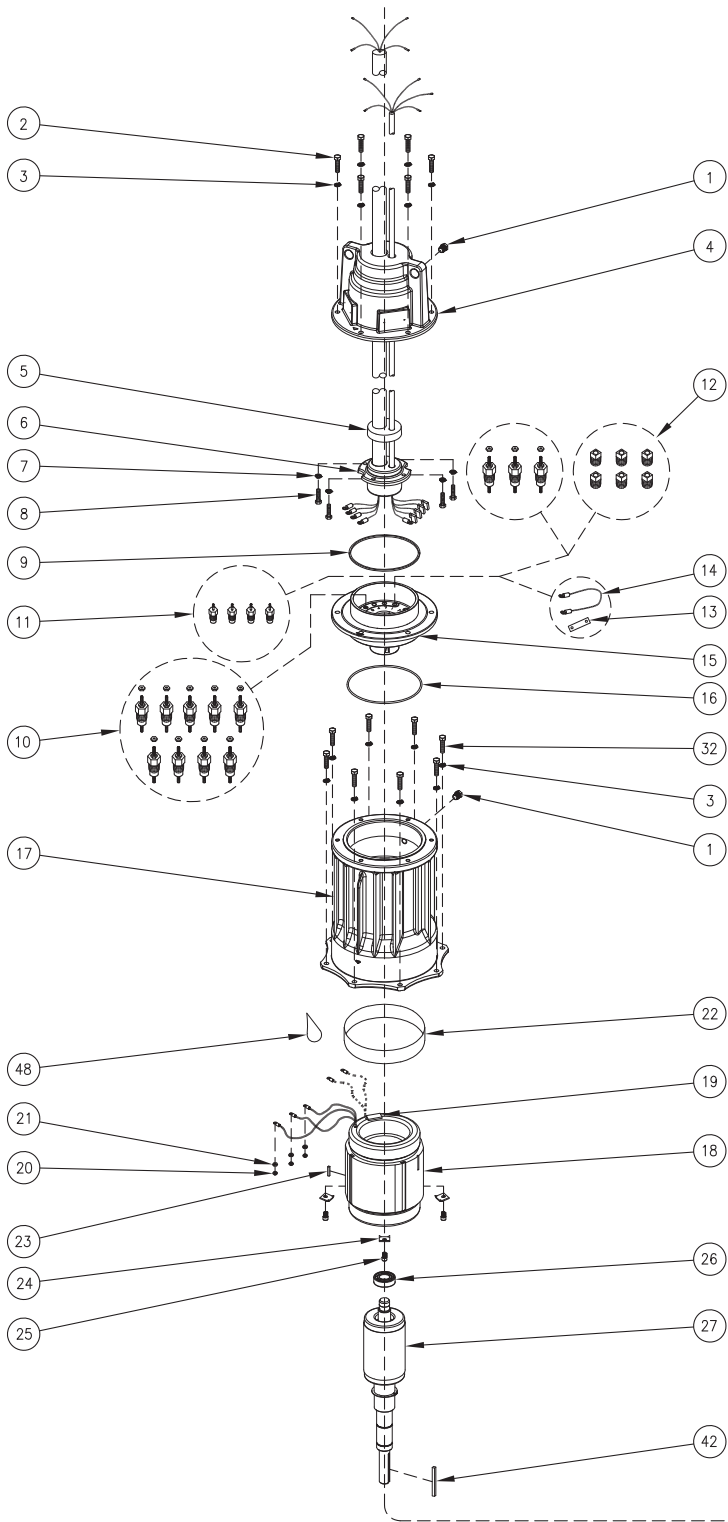

SK3333

72 HD PARTS LIST			
NUMBER	DESCRIPTION	QTY.	PART NO.
1	PLUG	3	011162
2	SCREWS	6	004532
3	WASHER, LOCK	23	004497
4	COVER	1	(SEE JOB FOLDER FOR BOM) 12GA, 8GA, or 4GA POWER CORD.
5	CORD SEAL	1	(SEE JOB FOLDER FOR BOM) 12GA, 8GA, or 4GA POWER CORD.
6	CORD AND CLAMP ASSEMBLY	1	(SEE JOB FOLDER FOR BOM) 12GA, 8GA, or 4GA POWER CORD.
7	WASHER, LOCK	4	006402
8	SCREWS, CORD CLAMP	4	001908
9	SEAL, COVER	1	015337 (STANDARD BUNA. SEE JOB FOLDER)
10	THRU WALL TERMINALS, POWER	3 OR 9	013340 (3 REQ'D FOR 200/3PH AND 575/3PH.) (9 REQ'D 230/460 3PH)
11	THRU WALL TERMINALS, SENSORS	4	003402
12	PLUG, TERMINAL HOLES	0 OR 6	016940 (6 REQ'D FOR 200/3PH AND 575/3PH)
13	JUMPER PLATE	4	006495 (4 REQ'D 230/460 ONLY)
14	JUMPER WIRE	1	015336 (1 REQ'D 230/460 ONLY)
15	UPPER BEARING HOUSING	1	015194
16	SEAL, UPPER BEARING HOUSING	1	011158 (STANDARD BUNA. SEE JOB FOLDER)
17	MOTOR HOUSING	1	015196
18	STATOR	1	(SEE JOB FOLDER FOR BOM)
19	THERMOSENSOR	1	016945
20	HEX WIRING NUTS	SEE BOM	013349
21	WASHER, BRASS	SEE BOM	013350
22	MOTOR SPACER	1	(SEE JOB FOLDER FOR BOM)
23	STATOR KEY	1	006492 (3PH)
24	MOTOR CLIP	3	006472
25	SOCKET HEAD SCREW	3	006701
26	BEARING, UPPER	1	006704
27	ROTOR	1	(SEE JOB FOLDER FOR BOM)
28	RETAINER RING, LOWER BEARING	1	157356
29	BEARING, LOWER	1	156641
30	MOISTURE SENSOR WIRES	1	015261 (MOISTURE SENSOR & WIRE KIT)*
31	SEAL	1	015338 (STANDARD BUNA. SEE JOB FOLDER)
32	SCREWS	16	012860
33	ADAPTER	1	156642
34	MOISTURE SENSORS	1	015261 (MOISTURE SENSOR & WIRE KIT)*
35	ROTARY SEAL, UPPER	1	006500 (STANDARD CARBON/CERAMIC SEE JOB FOLDER FOR BOM)
36	SNAP RING	1	006471
37	SEAL, SEAL RETAINER	1	015339 (STANDARD BUNA. SEE JOB FOLDER)
38	SEAL RETAINER	1	156615
39	SCREW, SEAL RETAINER	8	007768
40	ROTARY SEAL, LOWER	1	006500 (STANDARD CARBON/CERAMIC SEE JOB FOLDER FOR BOM)
41	IMPELLER SHIM PACK	1	010508
42	KEY, IMPELLER	1	012528
43	IMPELLER	1	(SEE JOB FOLDER FOR BOM)
44	WASHER, CUTTER	1	006454
45	SCREW, CUTTER	1	013368
46	SEAL, PUMP HOUSING	1	015339
47	PUMP HOUSING	1	(SEE JOB FOLDER FOR BOM)
48	OIL, 1 GALLON CAN	2	008419 (2 REQ'D)
49	SCREW, CUTTER PLATE	8	007768
50	DISC, CUTTER	1	155917
51	CUTTER	1	013570
52	NIPPLE, PIPE	3	157354
53	CAP, PIPE	3	157355
54	CUTTER SHIM PACK	1	013568

* ONE KIT REQUIRED PER PUMP

Disassembly Procedures

DUAL VOLTAGE MOTORS

230/460V pump stators are wound so they can be wired for either 230 or 460 volts. New pumps are shipped connected for the specific voltage ordered.

To change the voltage, remove the six screws (2) that secure the cover. Lift off the cover (4) being careful not to damage the seal ring (9). Change the wiring as required per the following diagram.

NOTE: ALL THREE PHASE CONNECTIONS
1. BLACK
2. WHITE
3. RED

TWO PLATES ARE STACKED ON THESE CONNECTIONS (FROM THE FACTORY) SO THAT THERE ARE 4 PLATES AVAILABLE. 4 PLATES ARE REQUIRED FOR 230 VOLT.

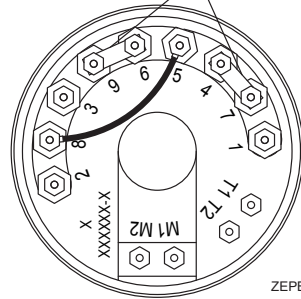
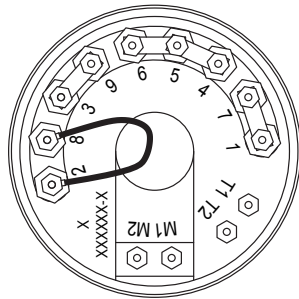

ZEPB0594

230 VOLT 3PH

460 VOLT 3PH

THREE PHASE STANDARD MOTOR,
VOLTAGE OPTIONS WIRING DIAGRAM

After changing the leads, lightly oil the seal ring (9). Ensure that the wire leads will not be pinched and position the cover (4) on the upper bearing housing (15), securing with screws (2).

Before installing a pump into a pit for operation, check the pump rotation, ensure that the wiring has been completed to proper power source and that the green lead of the power and sensor cords (see Power and Sensor Cord Lead identification illustration) is connected to a valid ground. Momentarily energize the pump, observing the direction of kick back due to starting torque. Rotation is correct if kick back is in the opposite direction of rotation arrow on the pump casing. If rotation is not correct, switching of any two power leads should provide the proper rotation.

OPERATION

Before putting the pump into operation, the following items should be checked to ensure that the pump is installed correctly.

- Electrical connections
- Pump rotation

Loss of performance is usually an indication of wear between the impeller and the casing. The gap created by this wear can be reduced by adding shims as instructed in disassembly and assembly sections of this manual.

DISASSEMBLY PROCEDURES

A. Before you begin...

1. Shut off pump.
2. Disconnect power source.
3. Remove pump from system.

B. When removing cutter (51)...

1. Complete Section A.
2. Immobilize the cutter (51) by placing a brass or aluminum rod in one of the holes in the cutter plate (50). Turn the cutter until it is against the rod in the correct direction to remove the cutter screw (45).

NOTE: It may be necessary to heat the hex head screw with a propane torch to soften the thread compound.

CAUTION Do not chip or nick the cutter while using the rod to immobilize the cutter.

3. Using a socket remove the cutter screw (45) and washers (3) (44).
4. Remove the cutter (51).
5. Remove the cutter shims (54).

NOTE: Count the number of shims removed so the same number and sizes can be installed upon reassembly.

C. When removing cutter plate (50)

1. Complete section A and B.
2. Remove the eight cutter plate screws (49) and remove the cutter plate (50).

D. When removing impeller (43)...

1. Complete Sections A and B.
2. Remove eight screws (32) and lockwashers (3) from pump housing (47).

3. Remove pump housing (47) and seal (46) from seal retainer (38).
4. Using two pry bars, carefully pry the impeller (43) from the shaft.
5. Remove the impeller shims (41).

NOTE: Count the number of shims removed so the same number and sizes can be installed upon reassembly.

6. Remove the square key (42) from the shaft.

E. When removing rotary seals (35 & 40)...

1. Complete Sections A, B and D.

WARNING Pump should be at room temperature. Seal and motor housing may be pressurized. Care should be used in removing pipe plugs (1) so that oil is not sprayed.

CAUTION Do not touch sealing face of the rotating section or the stationary section of the rotary seal (35 & 40) when removing or installing seal. Seal replacement should be done in shop atmosphere if possible.

2. Remove lower snap ring (36) from shaft.
3. Remove the spring holder and seal spring of the lower rotary seal (40) from the shaft. See rotary seal component placement diagram for part identification.
4. Remove the pipe plug (1) in the side of the adapter (33) and drain the oil from the chamber with the pump laying on it's side.
5. Remove the eight socket head screws (39) from the seal retainer (38).
6. Use two screw drivers to lightly pry the seal retainer (38) from the adapter (33). The remaining parts of the lower seal assembly will also be removed.
7. Press seal seat out of the seal retainer (38).
8. Remove the seal ring (37) from the seal retainer and inspect for damage.
9. Slowly remove the oil plug (1) from the side of the motor housing (17) (see warning above).
10. Turn the pump on it's side to drain the motor chamber oil.
11. Remove the upper seal snap ring (36) from the shaft and remove the spring holder and seal spring of the upper rotary seal (35) from the shaft.
12. Using a bearing puller or other suitable tools, pull the rotating section of the upper rotary seal (35) from the rotor shaft. If needed, carefully pry rotating section loose and pull off by hand.
13. The stationary seal can be pried with a screw driver. Be careful not to chip as chips may fall into motor.

NOTE: If the adapter and motor housing are going to be separated to work on the motor it may be easier to do so before removing the upper seal. When the rotor and bearing are pulled from the adapter it will strip the seal off the shaft on the lower side.

F. When removing the power and sensor cord assembly (6)...

1. Complete section A.
2. Remove the six screws (2) and lock washers (3) that secure the cover (4) to the motor housing (17).
3. Pry the cover (4) off using two pry bars.
4. Remove the power and sensor cord lead connections from the thru-wall terminals (10 & 11) in upper bearing housing (15). Set cover and cord assembly aside.
5. Remove seal ring (9) from the cover and inspect for damage.
6. To replace cord assembly. Remove four screws (8) and lock washers (7).
7. Using a small pry bar, pry around the edges of the cord clamp area of the cord and clamp assembly (6) to loosen it.
8. Remove the ground screw and disconnect the ground wire from the inside of the cover (4).
9. Pulling on the power leads on the inside of the cover, remove the cord and clamp assembly (6) and cord seal (5) from the cover. The entire length of the power and sensor cords will be pulled through the cover.

NOTE: It may take some wiggling and prying to loosen this assembly, because the rubber seal will have taken a set.

10. Inspect the cord seal (5) for damage.

G. When removing motor rotor (27)...

1. Complete sections A, B, and D
If the cord and cover assembly has been removed, two 3/8" eye bolts will be required when lifting the motor housing and stator off the unit.
2. Place the pump vertical on the work surface. The pump must be blocked or set back in pump housing (46) to allow shaft to extend out the bottom.
3. Remove eight screws (32) and lock washers (3) between motor housing (17) and adapter (33).
4. Lift the motor housing (17), upper bearing housing (15) and stator (18) up off the adapter (33) high enough to reach the moisture sensor wires (30) and unplug terminals from moisture sensors (34).
5. Finish lifting the motor housing (17) off the adapter (33). Be careful to lift the motor housing straight up, so as not to damage the stator windings or bearings.
6. Remove seal ring (31) from adapter (33) and inspect.
7. Using 90° retaining ring pliers, release the retaining ring (28) which secures the double row bearing (29) in the adapter (33).
8. Remove rotor assembly (27) from adapter (33).
9. Using a bearing puller, against the inner race, remove the lower bearing (29) and upper bearing (26) from the shaft. Replace the bearings if needed.

Assembly Procedures

NOTE: Bearings should be cleaned with volatile mineral spirits and relubricated with proper lubricants immediately after cleaning. Never dry bearings with compressed air, and never spin unlubricated bearings.

H. Motor Stator (18)...

1. Complete sections A, F and G.

NOTE: The six screws that hold the cover in place also hold the upper bearing housing to the motor housing.

2. Use two screwdrivers to pry the upper bearing housing (15) from the motor housing (17).
3. Turn the upper bearing housing (15) over and remove the hex nuts (20) which secure the motor leads to the thru-wall terminals (10) tagging each as it is disconnected. Disconnect the sensor wires from the thru-wall terminals (11).
4. Tuck the motor leads and sensor wires into the center of the stator so they will not be damaged when the stator is removed.
5. Turn the motor housing (17) over so that the bottom end is up. Hold the motor stator (18) and lightly tap the housing flange with a soft hammer until the stator comes out of the motor housing (17).

I. Removing sensor studs (34)...

1. Complete section A, section E #9, and section G #6.
2. Unscrew moisture sensors (34) from the adapter (33). The moisture sensor is equipped with a resistor. The resistor must be cut free before unscrewing sensors.

ASSEMBLY PROCEDURES

Pumps are reassembled in reverse order of disassembly. The following suggestions are offered.

NOTE: While the pump is dismantled, all gaskets, seal rings and retaining rings should be checked for wear and deterioration. Replace all worn items. Ensure that all parts are thoroughly cleaned before assembly.

A. Installing the sensor studs (34)...

1. Apply oil to threads of sensor studs (34).
2. Apply oil into threaded holes in adapter (33).
3. Screw sensor studs (34) into adapter (33). Apply 34 in-lbs of torque.
4. Place resistor leads into sensor tubing and crimp tubing.

B. Assembly of rotor (27)...

1. Inspect rotor to see that the snap ring is in place and snapped in the groove. This snap ring serves as a locator for the lower bearing.
2. Slip the retaining ring (28) over the lower end of the shaft.

NOTE: Before installing the bearing, wipe the bearing seats on the shaft clean and coat the seats with oil to prevent galling of the shaft as the bearings are pressed onto the shaft. A properly sized pressing sleeve should be used to install bearings, with pressure being applied to only the inner bearing race.

4. Install the lower ball bearing (29) and the upper ball bearing (26) on the rotor shaft (27).
5. Set the adapter (33) on blocks to allow the rotor shaft to clear the work surface when installed.
6. Install the rotor/bearings assembly into the adapter housing (33). Make sure the lower bearing is seated in the bearing pocket.
7. Using a pair of 90° retaining ring pliers, install the retaining ring (28) into the adapter (33) groove on top of the double row bearing (29).

C. Installing the motor spacer/stator (22 & 18)...

1. Install the motor spacer (22) into the motor housing (17). Make sure there is no dirt in the housing.
2. With the motor housing (17) sitting bottom side up, coat the stator area of the motor housing and the outside diameter of the stator (18) with oil.
3. Place the stator lead wires through the inside of the stator and pull them tight against the end turn winding so that they are not cut by the motor spacer (22) when the stator (18) is pressed into the motor housing (17).
4. While aligning the keyway in the stator (18) with the key slot in the motor housing (17) install the stator (18) (motor leads first) by pressing into the housing carefully so as not to damage any wires.

NOTE: A light press may be necessary for this step. Do not push on the windings of the stator.

5. Install the stator key (23) in the slot.
6. Install the three motor clips (24) and screws (25) using thread locking compound on the screw threads.
7. Place the moisture sensor wires (30) through the wire chase between the motor housing and stator. The sensor wires should hang out from the bottom of the housing several inches.

D. Installing upper bearing housing (15) to motor housing (17)...

1. Pull motor leads through top of housing.
2. Lightly oil and position the seal ring (16) into groove in upper bearing housing (15). Oil motor housing upper inside diameter at this time.
3. Suspend the upper bearing housing (15) over the motor housing (17) and make wiring connections per proper wiring diagram and lead numbers.

NOTE: The motor leads go to the numbered terminals, the moisture sensor wires to M1 and M2 and the thermosensor wires to T1 and T2.

4. Tuck the wires in so as not to damage them. Avoid getting them pinched or near moving parts and lower into place on motor housing (17).
5. Aligning holes in upper bearing housing (15) and motor housing (17), press upper bearing housing (15) into place making sure not to cut seal ring (16) as unit is pressed into place.
6. Temporarily fasten the upper bearing housing (15) to motor housing (17) with a screw.

E. Installing the motor housing/stator on adapter/rotor...

1. Invert motor housing and tuck lead wires out of the way of any moving parts.
2. Lightly oil and position the seal ring (31) around the pilot shoulder of the adapter (33).
3. With the rotor/adapter assembly upright on blocks, suspend the motor housing/stator unit over it.
4. Slowly lower the motor housing/stator unit down over the rotor aligning the rotor and stator opening. Make sure not to let the rotor or any other parts contact the stator windings so they will not be damaged. Lower the housing until the moisture sensor wires (30) can be plugged onto the moisture sensors (34).
5. Tuck the moisture sensor wires away from the rotor while lowering the motor housing/stator unit into place on the adapter.
6. Secure the motor housing/stator (17) to the adapter (33) with eight screws (32) and lock washers (3). Torque to 175-195 in-lbs.

NOTE: The small arrowheads on the motor housing and adapter need to be approximately aligned for proper orientation.

F. Installing cord and cover assembly...

NOTE: The cords will come from the factory as a cord and clamp assembly (6). The assembly consists of the power cord, the sensor cord, the wire terminals, the clamp and the potting compound between the cords and clamp.

1. Unroll the cords of the cord and clamp assembly (6) and slide the cord seal (5) down the cords to the clamp.
2. From the inside of the cover (4) place the cords of the assembly (5 & 6) through the holes and pull through the top.
3. Push the cord seal (5) into its pocket inside the cover (4). Push the clamp tight against the seal (5).
4. Apply thread locker compounds to the screws (8) and install into clamp (6) along with lock washers (7). Using a cross pattern, tighten the screws to the seal clamp evenly. Torque screws to 140 in-lbs.
5. Apply thread locker compound to ground screw and install ground wires to cover (4).
6. Lightly oil and install seal ring (9) on shoulder of upper bearing housing (15).
7. Suspend the cord and cover assembly over the motor housing and make wiring connections per the proper wiring diagram.

NOTE: The motor leads go to the numbered terminals, the moisture sensor wires to M1 and M2 and the thermosensor wires to T1 and T2.

NOTE: If motor is dual voltage 230/460V, install jumper plates (13) and jumper wire (14) on terminals (10) and secure with brass hex nuts (20) per proper wiring connection diagram.

NOTE: If a temporary screw is holding the upper bearing housing to the motor housing, remove it at this time.

8. Tuck the wires into the cover assembly as installing the cover into place.
9. Secure the cover (4) to the motor housing (17) with six screws (2) and six lock washers (3). Torque screws to 175-195 in-lbs.

NOTE: The small arrowheads on the castings are to be aligned for proper orientation.

Assembly Procedures (continued)

G. Installation of rotary seals and seal retainer...

CAUTION Make sure all seal faces remain free of dirt particles. Apply a light coat of oil to seal faces before installing.

1. Refer to rotary seal component placement diagram for relative positioning of seal parts.
2. Apply a coating of oil to the seal seat and the bore of the adapter (33), and using a nonmetallic sleeve, press the seat into position in the adapter.

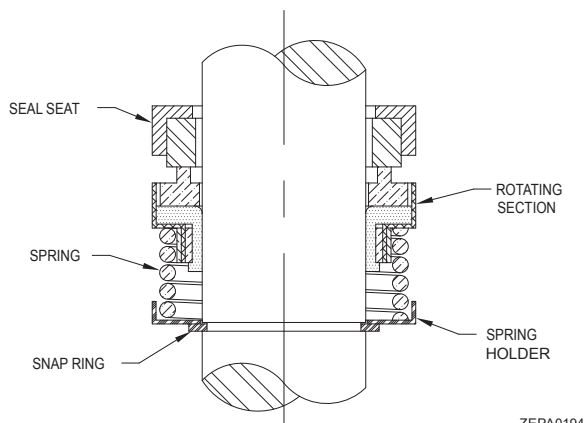

**ROTARY SEAL COMPONENT
PLACEMENT DIAGRAM**

ZEPA0194

3. Apply Dielectric oil to the shaft and to the inside diameter of the rotating section of rotary seal (35). Push the rotating section onto the shaft in a continuous motion until the seal faces meet.
4. Install the spring and spring holder over the shaft and seat against the rotating section. Compress the spring as necessary and install retaining ring (36) in the groove of the motor shaft.
5. Lightly oil and install seal ring (37) on the seal retainer (38).
6. Press the seal retainer (38) into the adapter (33) and secure with the eight socket head screws (39).
7. Install the seal seat and rotating section of the lower rotary seal assembly (40) into the seal retainer (38) in the same manner described in steps -4 above.

H. Installing the impeller...

1. Install the proper number of impeller shims (41) on the shaft to give the face of the impeller (43) a clearance of 0.030 inch with the wearing face of the pump housing (47) (see impeller clearance diagram.)
2. Install the square key, (42) in the groove in the shaft.
3. Install the impeller (43).

I. Installing the pump housing (47)...

1. Lightly oil and install the seal ring (46) on the seal retainer (38).
2. Install the pump housing (47) on the seal retainer (38). Securing it with the eight screws (32) and lock washers (3).
3. Torque screws to 175-195 in/lbs.

Note: Cutter plate and cutter can be replaced with new service parts or resurfaced by grinding. Resurfacing is accomplished by surface grinder both cutter plate and cutter to a 32 micro finish. Do not attempt grinding in the field. Send parts to a qualified machine shop or return to the factory for repair. The cutter plate and cutter shims are a matched set. Keep parts together. Measure disc before and after resurfacing, the cutter plate and cutter must be flat within 0.001". If the plate has been surface ground, it will be necessary to remove shims to compensate for the material removed from the plate plus any amount over 0.008" measured in the field before the cutter and plate were disassembled from the pump.

J. Installing the cutter plate (50)...

1. Carefully clean the area of pump housing (47) where the cutter plate (50) will be installed.
2. Install cleaned cutter plate (50) on the pump housing (47) with eight cutter plate screws (49).

Note: When the cutter plate is installed in the proper direction the eight radial relief slots will be facing out towards the cutter.

K. Installing the cutter (51)...

1. Install the proper amount of shims (54) on the shaft to obtain the proper running clearance between the cutter plate (50) and cutter (51).
2. Install the cutter (51) onto the shaft.
3. Install the screw (45), lockwasher (3) and flat washer (44) using thread locking

compound and torquing to 175-195 in/lbs.

Note: Immobilize the cutter by placing a aluminum or brass rod in one of the holes in the cutter plate.

CAUTION Do not chip or nick the cutter while using the rod to immobilize the cutter.

4. With the pump in the vertical position to remove end play, measure the running clearance between cutter (51) and cutter plate (50) using a feeler gauge. Repeat 1 thru 3 until .004" to .008" clearance is obtained. (See cutter clearance diagram on page 6).

Leak Test

(Before oiling pump) Perform a leak test on the pump seals by installing a regulated air supply into the holes (1/4" NPT access) the motor chamber, seal chamber and cover chamber must be checked. The pressure of the air supply should be set at approximately 9 psi. Submerge the pump in clear water watching for small air bubbles around square ring seals, rotary seal, cord connection, and oil fill plugs.

NOTE: Make certain that the pump is placed in the water so that no areas are present that would trap air (such as the cavity around the lower rotary seal), not allowing the bubbles to rise to the water surface.

If it is not possible to leak test the pump using the submersion method, a regulated air supply with a (0-15 psi) air gage can be installed in the fill holes. The pump to be pressurized and held at 9 psi. After removing the air supply, the pressure should not drop more than 1/2 psi in a 24 hour period.

L. Oiling and final assembly...

1. After leak testing has been completed, clean pipe plugs and reapply pipe dope or Teflon tape. Install pipe plug (1) in cover (4).
2. The following electrical tests **must** be performed:
 - a) Using a Hypot or Megger, test all leads to case ground.
 - b) Check that there is continuity from the ground wire(s) to ground.
 - c) Check that there is no continuity from all lead wires to ground.
 - d) Check that there is continuity between the thermosensor wires,
 - e) Check that the resistance between moisture sensor wires is 330K ohms.
3. With the pump laying on it's side with the oil fill hole up fill the seal chamber cavity with an anti-wear non-detergent, rust inhibiting, paraffining oil of approximately 100 SUS. (See table below for acceptable type of oil.)

Refiner	Product Name
Arco	Duro 22 or 32
Exxon	Teresstic 22 or 32 or acceptable equal
Chevron	Clarity Hydraulic Aw ISO22 or ISO32

4. Clean pipe plugs (1) and reapply pipe dope or Teflon tape. Install pipe plug in adapter (34).
5. While pump is on it's side place approximately one quart of oil in motor housing (17) (Use the same oil as used in the seal cavity.)
6. Set the pump upright and finish filling the motor chamber (17) with oil until it runs back out the fill hole. With the oil running out the fill hole, the oil will be at the proper level for the top bearing.

WARNING Do not over fill.

7. Clean pipe plug (1) and reapply pipe dope or Teflon tape. Install pipe plug in motor housing (17).

IMPELLER CLEARANCE DIAGRAM

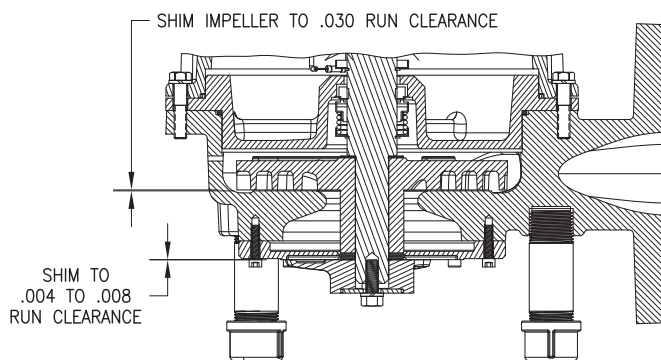

SK3331

Wiring Diagrams

3 PHASE 72 HD SERIES

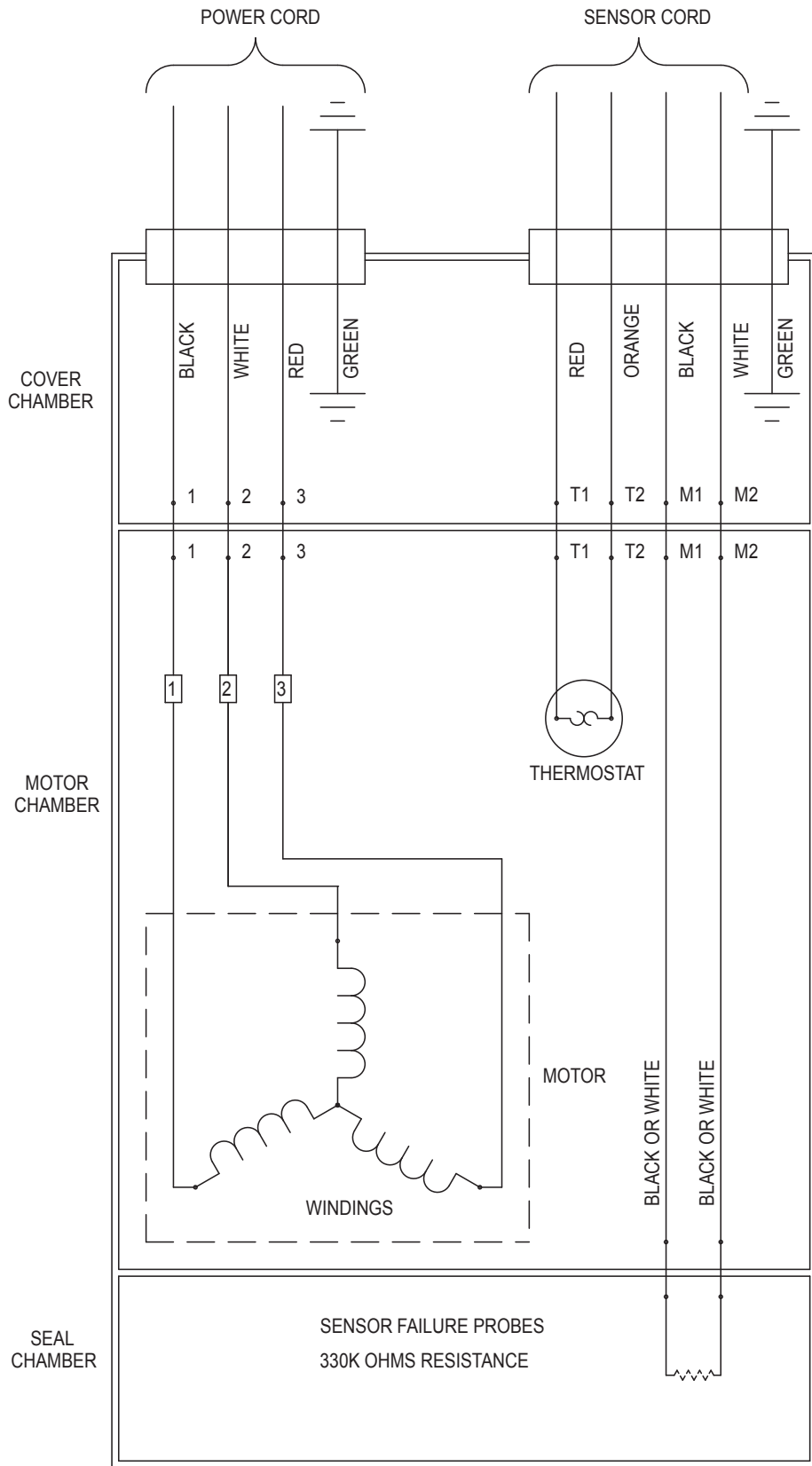

A00621

Service Checklist & Trouble Shooting



▲ WARNING ELECTRICAL PRECAUTIONS Before servicing a pump, always shut off the main power breaker to the panel and then disconnect the pump - making sure you are wearing insulated protective sole shoes and are not standing in water. Under flooded conditions, contact your local electric company or a qualified licensed electrician for disconnecting electrical service prior to pump removal.

▲ WARNING Submersible pumps contain oils which become pressurized and hot under operating conditions - **allow 2-1/2 hours after disconnecting before attempting service.**

CONDITION

A. Pump will not start or run.

Steps	Check Voltage At	If No Voltage	If Voltage
No. 1	Line terminals in pump's control panel L1 - L2 - L3 (3 Phase).	Check Disconnect switch, line fuse, and/or circuit breakers in power supply circuit.	Proceed to No. 2.
No. 2	Pump motor terminals in pump's control panel T1 - T2 - T3.	Check for control circuit voltage. Check out magnetic starter contacts, thermal overloads, and float switches.	Check pump for ground, and bound impeller or cutter.

COMMON CAUSES

B. Motor overheats and trips overload or blows fuse.

- Incorrect Voltage
- Unbalanced power source
- Incorrect motor rotation
- Negative or low head
- Excessive water temperature
- Impeller or seal mechanically bound
- Defective capacitor or relay
- Motor shorted
- Lost one line in a Three Phase unit

C. Pumps starts and stops too often.

- Check valve stuck open
- Level controls out of adjustment
- Temperature sensor tripping
- Thermal overload switch out of adjustment or defective
- Pit too small

D. Pump will not shut off.

- Debris under float switch
- Float travel obstructed
- Defective or damaged float switch
- Magnetic starter contacts shorted
- Air lock - check vent hole

E. Pump operates but delivers little or no water.

- Check for plugged Pump housing, discharge pipe or sticking check valve
- Vent hole clogged or not drilled
- Discharge head exceeds pumps capacity
- Low or incorrect voltage
- Incorrect motor rotation
- Defective capacitor

F. Drop in head and/or capacity after a period or use.

- Increase Pipe Friction
- Clogged line or check valve
- Abrasive material & chemical, deteriorated impeller and pump housing

If the above check list does not uncover the problem, consult the factory - Do not attempt to service or otherwise disassemble pump.