

Product information presented here reflects conditions at time of publication. Consult factory regarding discrepancies or inconsistencies.



MAIL TO: P.O. BOX 16347 • Louisville, KY 40256-0347
 SHIPTO: 3649 Cane Run Road • Louisville, KY 40211-1961
 (502) 778-2731 • 1 (800) 928-PUMP • FAX (502) 774-3624

Visit our web site:
zoellerengineered.com



INSTALLATION PROCEDURES

Z-Rail® Disconnect System



1-1/4" NPT Horizontal Discharge Progressing Cavity Grinder Pumps

GENERAL INFORMATION

These instructions cover Zoeller's Z-Rail® Disconnect System for use with 1-1/4" NPT horizontal discharge pumps. We also offer disconnects for pumps with 1-1/4" thru 3" NPT vertical discharges (see ZM1710 and ZM2818) and 2-1/2" thru 6" flanged horizontal discharge pumps (see ZM1170).

INSTALLING RAIL SYSTEM PARTS

Disconnect Fitting and Rails:

- Lower the disconnect fitting into the basin.
- 1A. Install the (4) square rubber pads Item 13 on the studs before placing the disconnect fitting. PADS ARE TO BE USED WITH 50 HZ/ HORIZONTAL DISCHARGE PROGRESSING CAVITY PUMPS. SEE SK3199.
- Position the disconnect fitting by dropping a plumb line from the center of pipe supports, located on top rail support, to center of pipe supports cast on the fitting. Level its mounting flange in two directions 90° to each other. Mark the position of the fitting, holding down bolts through the holes in the base.
- Move the disconnect fitting aside to allow for installation of 1/2" mounting bolts (not included). Secure fitting into mounting bolts.
- Cut the 3/4" pipe guide rails (supplied by others) to the proper length and install them between the upper rail supports at the top of the basin and the pins on the disconnect fitting. It is recommended that the guide rails are to be schedule 40, galvanized or stainless steel.

IMPORTANT: Discharge pipe and guide rails must be parallel if intermediated guide bracket is used.

INSTALLING INTERMEDIATE GUIDE BRACKET (Required for each 12 feet of basin depth)

- Remove guide rails and cut a piece from each one. The amount to cut from each one must be determined to permit installing the intermediate guide bracket in the desired location. After cutting, the pipes must be exactly the same length.
- Place the cut pieces of pipe over the guide rail pins located in the base.
- Set the intermediate guide bracket in position with guides into pipe. Put U-Bolt around discharge pipe and tighten lightly.
- Measure distance from pipe support on intermediate guide bracket to pipe support on top rail bracket. Cut two (2) guide rails to this length. Put guide rails in place and tighten screws in top rail bracket.
- Recheck rails; they must be straight and plumb. Move intermediate guide bracket if necessary to perfectly align. Rail after alignment is secured, tighten nuts on U-Bolt.

- If a second intermediate guide bracket is used, the above procedure is followed for installation.

ATTACHING THREADED DISCONNECT TO PUMP

- Thread guide plate and elbow assembly into pump housing discharge.
- Tighten and align slide assembly so that the guide plate is level and square to the pump body.
- Remove legs from pump by removing nuts and washers. Save legs and hardware.
- Attach anti-rotation bracket, supplied with rail system, to pump housing using one nut and washer from leg removal. Attach opposite end of anti-rotation bracket to guide plate using supplied hex head screw, lock and flat washers.
- Attach lifting bail (P/N 10-0789) to the pump, if not factory installed.

INSTALLING PUMP AND DISCONNECT

IMPORTANT: When lifting pump up and down the guide rails, the pump should be slightly tipped forward toward the discharge and plumb (vertical) from side to side when facing the discharge.

Position pump so the guide rails are located in the slots of the guide plate. Slowly lower the pump down the guide rails to the base. The machined pads on the guide plate should come to seat in the inclined surface on the arms.

After lowering the pump down the guide rail, secure the upper end of the lifting cable to the top rail support to keep it from falling into the pit.

SPECIFICATIONS				
Rail System	Pump Discharge	Rail System Discharge	Materials of Construction*	Weight (lbs)
39-0137	1-1/4" H	2" V reduced to 1-1/4"	powder coated ductile iron	41
39-0138	1-1/4" H	2" V reduced to 1-1/4"	powder coated ductile iron w/ SS Upper Support	43
39-0139	SS intermediate rail bracket 1-1/4", 1-1/2" & 2" discharge - required for each 12' of basin depth			4
10-0789**	SS lifting bail for 7020, 7021 Series			1

* Disconnect fitting, guide rail plate, rail guide, upper rail support bracket
 ** Lifting bails are required on the following models to balance pump and rail plate evenly. Other models already include proper lifting bail.

Models: 39-0137 and 39-0138

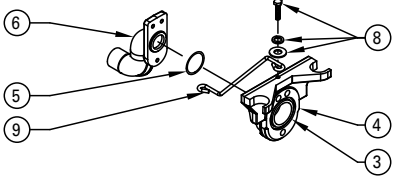

PART NO.	DESCRIPTION
1	DISCONNECT FITTING
2	P/N 152878 - COMPLETE SLIDE ASSEMBLY INCLUDES PARTS 3,4,5,6,8,9
3	SEALING PLATE O-RING
4	GUIDE PLATE
5	SEALING ELBOW O-RING
6	PUMP ELBOW
7	BELL REDUCER
8	HEX HEAD SCREW, LOCK WASHER AND FLAT WASHER
9	ANTI-ROTATION BRACKET
*10	(39-0139) STAINLESS STEEL INTERMEDIATE RAIL SUPPORT AND U-BOLT
11	DUCTILE IRON UPPER RAIL SUPPORT OR STAINLESS STEEL UPPER RAIL SUPPORT
12	BY OTHERS-TWO 3/4" RAIL PIPES

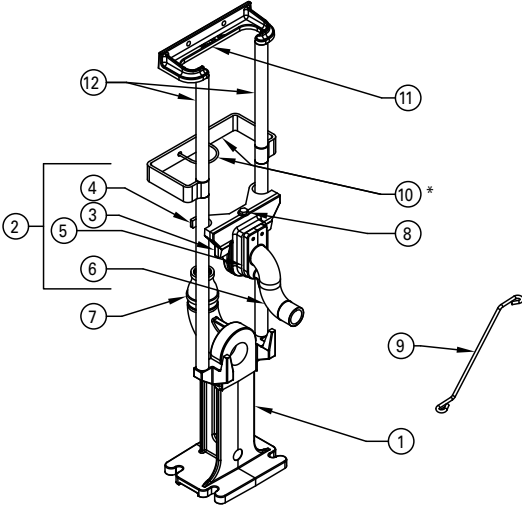

*OPTIONAL - REQUIRED FOR EACH 12' SECTION OF RAIL PIPE.

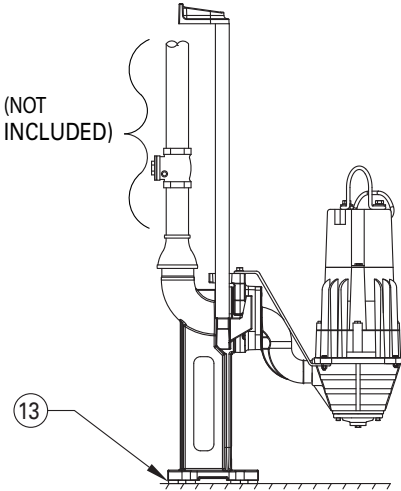
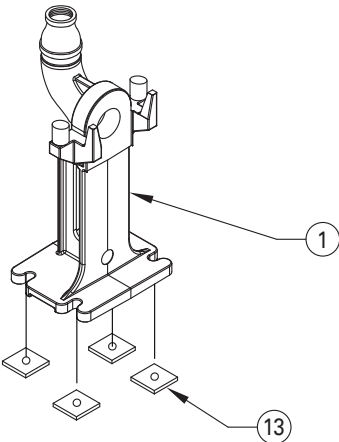
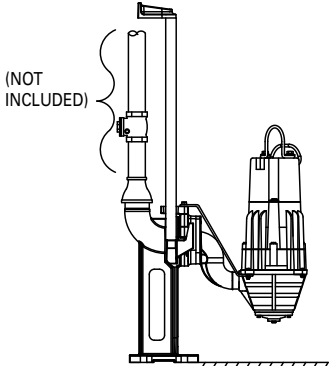

SK2987

PART NO.	DESCRIPTION
1	DISCONNECT FITTING
13	RUBBER PAD

SK3199