

Trusted. Tested. Tough.™

Product information presented here reflects conditions at time of publication. Consult factory regarding discrepancies or inconsistencies.



SECTION: Z2.20.160

ZM2313

0214

Supersedes

0106

**MAIL TO:** P.O. BOX 16347 • Louisville, KY 40256-0347  
**SHIP TO:** 3649 Cane Run Road • Louisville, KY 40211-1961  
 (502) 778-2731 • 1 (800) 928-PUMP • **FAX** (502) 774-3624

**visit our web site:**  
[zoellerengineered.com](http://zoellerengineered.com)



**62 HD SERIES DIMENSIONAL DATA**  
**4" FLANGED DISCHARGE UNITS**  
 Dry Pit Mounted  
 Models: 6220 - 6223

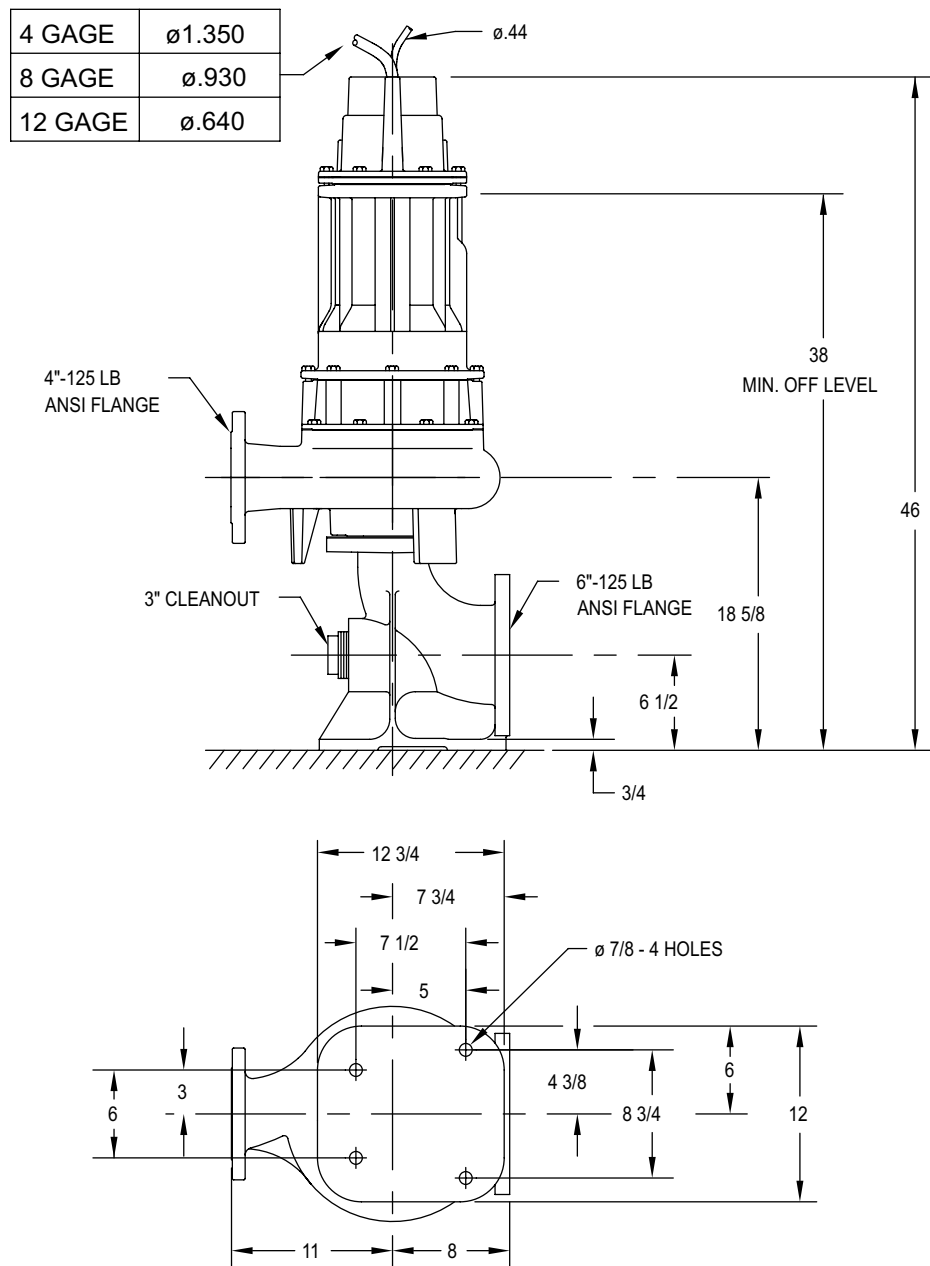

NOTE: All dimensions in inches unless otherwise noted.

© Copyright 2014 Zoeller Co. All rights reserved.

ZEPA0583