

Trusted. Tested. Tough.®

ZM1788

1120

Supersedes

0714

Product information presented here reflects conditions at time of publication. Consult factory regarding discrepancies or inconsistencies.



MAIL TO: P.O. BOX 16347 • Louisville, KY 40256-0347
 SHIP TO: 3649 Cane Run Road • Louisville, KY 40211-1961
 (502) 778-2731 • 1 (800) 928-PUMP • FAX (502) 774-3624

Visit our website:
zoellerengineered.com



REPAIR MANUAL

71 SERIES SUBMERSIBLE GRINDER UNITS

Since 1939 the name Zoeller® has represented the standard for submersible dewatering and sewage pumps. The same high quality workmanship and easy maintenance design has been incorporated into this line of heavy-duty submersible grinder pumps.

This manual incorporates the parts list and repair instructions into one document to aid in the ownership of a Zoeller® submersible grinder wastewater product. Please read and review this manual before repairing

the product. Follow the steps and procedures listed on ZM1074 for a proper start-up upon installation. Many items contained within, when followed correctly, will not only ensure a long and problem-free life for the pump, but also save time and money during installation. Reference ZM1789 for owner's manual on 71 Series Pumps. Should further assistance be necessary please call our Product Support Department at 1-800-928-PUMP (7867).

Table of Contents

Safety Instructions	1
Replacement Parts List	2-3
Disassembly Procedures.....	4
Assembly Procedures.....	5-6
Pump Wiring Diagrams	7
Service Checklist.....	8

To Order Replacement Parts

PLEASE FURNISH THE FOLLOWING INFORMATION:

- Model Number
- Part Number of Pump
- Serial Number
- System Voltage
- Replacement Part Number and Description. (refer to pages 2 & 3)

Short Term Storage

Storage of six months or less will not damage the submersible pump. However, to ensure the best possible protection, the following is advised:

- Store pump inside whenever possible or cover with some type of protective covering.
- Tape or seal in plastic bag the terminal ends of wire leads.
- Spray coat unpainted surfaces with rust-inhibiting oil.
- See ZM1789-Owner's Manual before start-up.

Safety Instructions

TO AVOID SERIOUS OR FATAL PERSONAL INJURY OR MAJOR PROPERTY DAMAGE, READ AND FOLLOW ALL SAFETY INSTRUCTIONS IN THIS MANUAL AND ON THE PUMP.

THIS MANUAL IS INTENDED TO ASSIST IN THE INSTALLATION AND OPERATION OF THIS UNIT AND MUST BE KEPT WITH THE PUMP.



This is a **SAFETY ALERT SYMBOL**.

When you see this symbol on the pump or in the manual, look for one of the following signal words and be alert to the potential for personal injury or property damage.

▲ DANGER Warns of hazards that **WILL** cause serious personal injury, death or major property damage.

▲ WARNING Warns of hazards that **CAN** cause serious personal injury, death or major property damage.

▲ CAUTION Warns of hazards that **CAN** cause personal injury or property damage.

▲ NOTICE INDICATES SPECIAL INSTRUCTIONS WHICH ARE VERY IMPORTANT AND MUST BE FOLLOWED.

THOROUGHLY REVIEW ALL INSTRUCTIONS AND WARNINGS PRIOR TO PERFORMING ANY WORK ON THIS PUMP.

MAINTAIN ALL SAFETY DECALS.

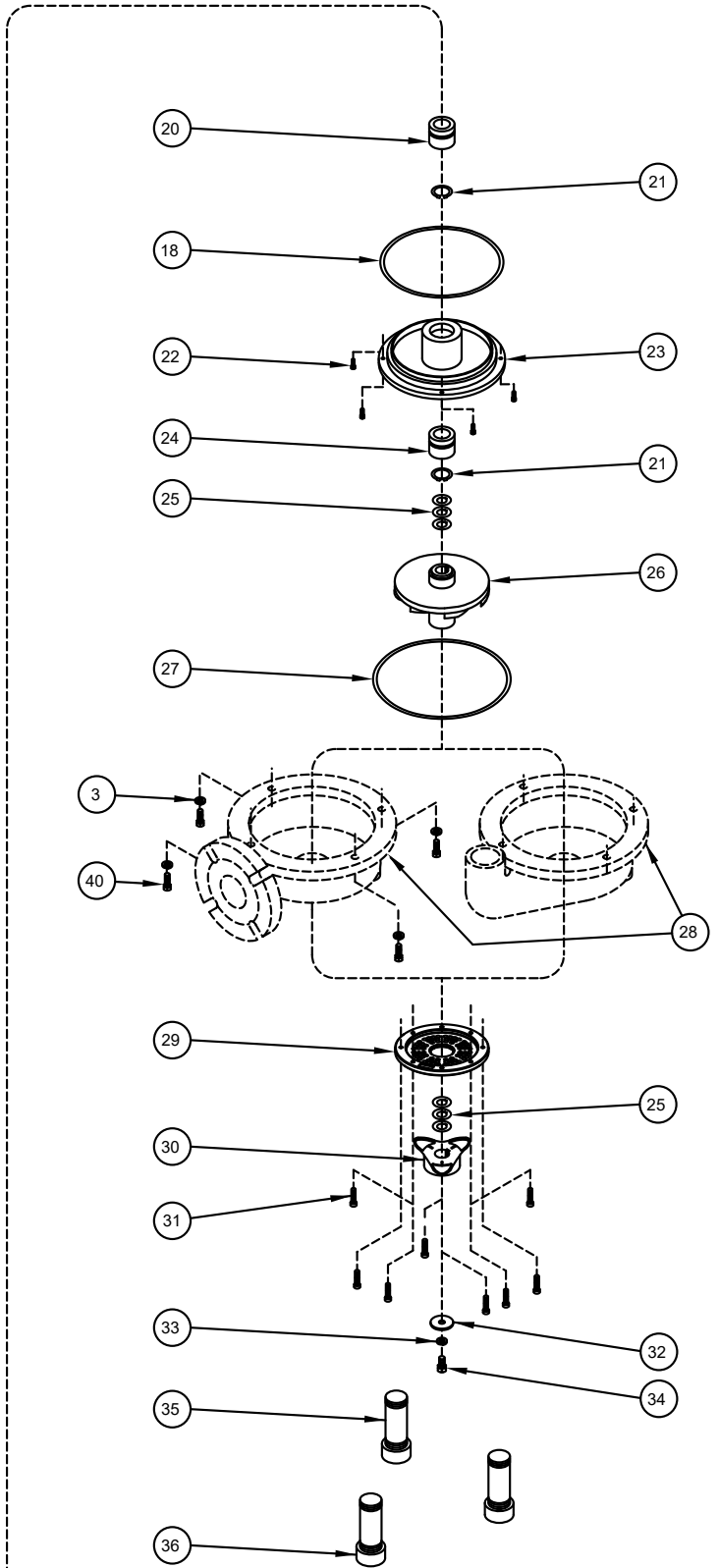
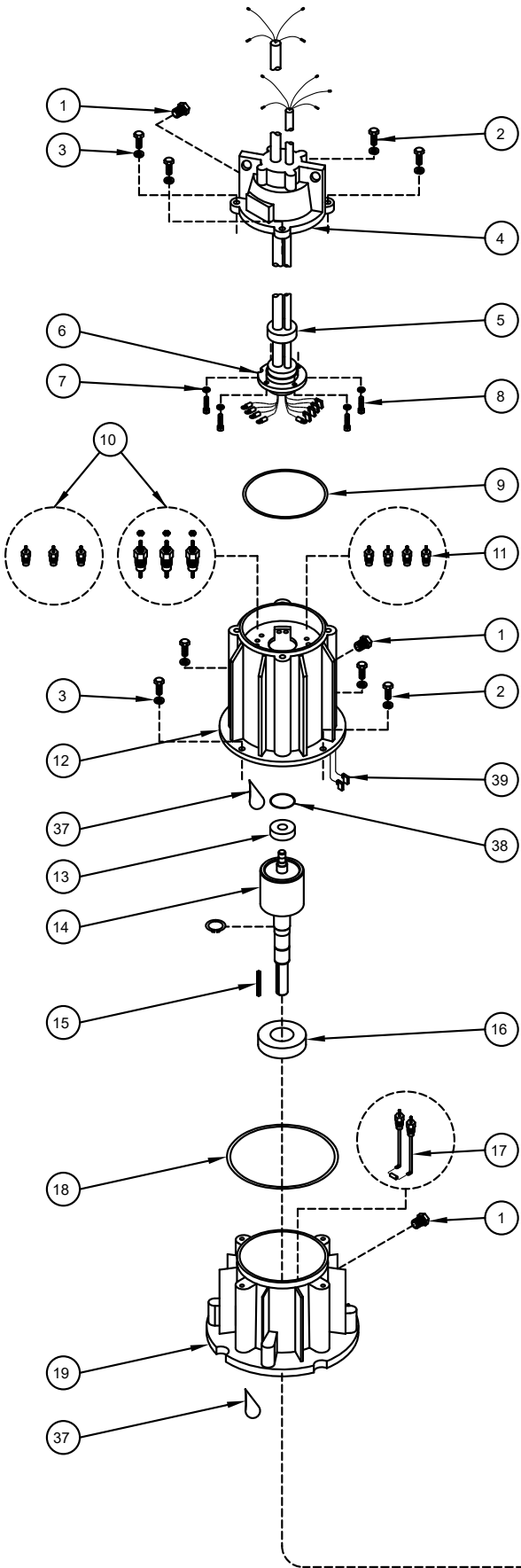

71 SERIES GRINDER PARTS LIST

NUMBER	DESCRIPTION	QTY.	PART NO.
1	PLUG	3	011162
2	SCREWS	8	006451
3	WASHER, LOCK	12	004497
4	COVER	1	(see job folder for BOM) small or large power cord hole.
5	CORD SEAL	1	(see job folder for BOM) 12 or 8 ga.
6	CORD AND CLAMP ASSEMBLY	1	(see job folder) 12 or 8 ga. (013565, 013567)
7	WASHER, LOCK	4	002255
8	SCREWS, CORD CLAMP	4	004416
9	SEAL, COVER	1	011157 (standard buna see job folder)
10	THRU WALL TERMINALS, POWER	3	(see job folder for BOM)
11	THRU WALL TERMINALS, SENSORS	4	003402
12	MOTOR HOUSING AND STATOR	1	(see job folder for BOM) note: moisture sensor wire must be installed.
13	BEARING, UPPER	1	010069
14	ROTOR	1	(see job folder for BOM)
15	KEY, IMPELLER	1	012528
16	BEARING, LOWER	1	012516 (note special instructions for installing this bearing the correct directions.)
17	MOISTURE SENSORS	1	015261 (moisture sensor and wire kit)*
18	SEAL, MTR HSG. / SEAL RETAINER	2	011158 (standard buna see job folder)
19	ADAPTER HOUSING	1	012513
20	ROTARY SEAL, UPPER	1	008165 (standard carbon/ceramic see job folder for BOM)
21	SNAP RING	2	013633
22	SCREW, SEAL RETAINER	4	007774
23	SEAL RETAINER	1	012511
24	ROTARY SEAL, LOWER	1	008165 (standard carbon/ceramic see job folder for BOM)
25	SHIM PACK	1	013568
26	IMPELLER	1	(see job folder for BOM)
27	SEAL, PUMP HOUSING	1	006478 (standard buna see job folder)
28	PUMP HOUSING	1	(see job folder for BOM)
29	CUTTER PLATE	1	155917
30	CUTTER	1	013570
31	CUTTER PLATE SCREWS	8	012529
32	CUTTER/IMPELLER WASHER	1	006454
33	LOCK WASHER	1	004497
34	CUTTER/IMPELLER SCREW	1	013368
35	LEGS	3	013335
36	FEET	3	006489
37	OIL	2	008419 (requires (2) one gal. cans)
38	PRELOAD SPRING	1	012595 (after manufacture's Date 2/2000)
39	MOISTURE SENSOR WIRES	1	011160 (see job folder for BOM)
40	SCREWS	4	012860

*015261 moisture sensor kit; one kit required per pump.

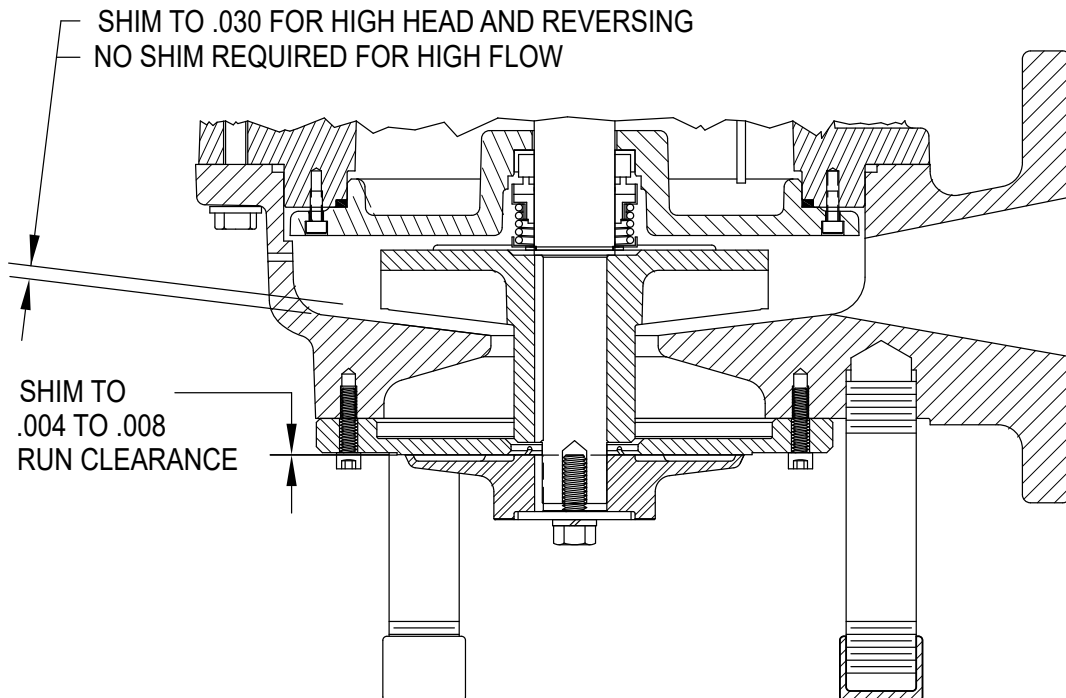

CUTTER AND IMPELLER CLEARANCE DIAGRAM

Disassembly Procedures

DISASSEMBLY PROCEDURES

A. Before you begin...

1. Shut off pump.
2. Disconnect power source.
3. Remove pump from system.

B. When removing cutter (30)...

1. Complete Section A.
2. Immobilize the cutter (30) by placing an brass or aluminum rod in one of the holes in the cutter plate (29). Turn the cutter until it is against the rod in the correct direction to remove the cutter screw (34).

NOTE: It may be necessary to heat the hex head screw with a propane torch to soften the thread compound.

▲ CAUTION Do not chip or nick the cutter while using the rod to immobilize the cutter.

3. Using a socket remove the cutter screw (34) and washers (33) (32).
4. Remove the cutter (30).
5. Remove the cutter shims (25).

NOTE: Count the number of shims removed so the same number and sizes can be installed upon reassembly.

C. When removing cutter plate (29)

1. Complete section A and B.
2. Remove the eight cutter plate screws (31) and remove the cutter plate (29).

D. When removing impeller (26)...

1. Complete Sections A and B.
2. Remove four screws (40) and lockwashers (3) from pump housing (28).
3. Remove pump housing (28) and gasket (27) from adapter housing (19).
4. Using two pry bars, carefully pry the impeller (26) from the shaft.
5. Remove the impeller shims (25).

NOTE: Count the number of shims removed so the same number and sizes can be installed upon reassembly.

6. Remove the square key (15) from the shaft.

E. When removing rotary seals (20 & 24)...

1. Complete Sections A, B and D.

▲ WARNING Pump should be at room temperature. Seal and motor housing may be pressurized. Care should be used in removing pipe plugs (1) so that oil is not sprayed.

▲ CAUTION Do not touch sealing face of the rotating section or the stationary section of the rotary seal (20 & 24) when removing or installing seal. When seal replacement should be done in shop atmosphere if possible.

2. Remove lower snap ring (21) from shaft.
3. Remove the spring holder and seal spring of the lower rotary seal (24) from the shaft. See rotary seal component placement diagram for part identification.
4. Remove the pipe plug (1) in the side of the adapter (19) and drain the oil from the chamber with the pump laying on it's side.
5. Remove the four socket head screws (22) from the seal retainer (23).
6. Use two screw drivers to lightly pry the seal retainer (23) from the adapter (19). The remaining parts of the lower seal assembly will also be removed.
7. Press seal seat out of the seal retainer (23).
8. Remove the seal ring (18) from the seal retainer and inspect for damage.
9. Slowly remove the oil plug (1) from the side of the motor housing (12) (see warning above).
10. Turn the pump on it's side to drain the motor chamber oil.
11. Remove the upper seal snap ring (21) from the shaft and remove the spring holder and seal spring of the upper rotary seal (20) from the shaft.
12. Using a bearing puller or other suitable tools, pull the rotating section of the upper rotary seal (20) from the rotor shaft. If needed, carefully pry rotating section loose and pull off by hand.
13. The stationary seal can be pried with a screw driver. Be careful not to chip as chips may fall into motor.

NOTE: If the adapter and motor housing are going to be separated to work on the motor it may be easier to do so before removing the upper seal. When the rotor and bearing are pulled from the adapter it will strip the seal off the shaft on the lower side.

F. When removing the power and sensor cord assembly (6)...

1. Complete section A.
 2. Remove the four screws (2) and lock washers (3) that secure the cover (4) to the motor housing (12).
 3. Pry the cover (4) off using two pry bars.
 4. Remove the power and sensor cord lead connections from the through wall terminals (10) and (11) in motor housing (12). Set cover and cord assembly aside.
 5. Remove seal ring (9) from the cover and inspect for damage.
 6. To remove cord assembly. Remove four screws (8) and lock washers (7).
 7. Using a small pry bar, pry around the edges of the cord clamp area of the cord and clamp assembly (6) to loosen it.
 8. Remove the ground screw and disconnect the ground wires from the inside of the cover (4).
 9. Pulling on the power leads on the inside of the cover, remove the cord and clamp assembly (6) and seal (5) from the cover. The entire length of the power and sensor cords will be pulled through the cover.
- NOTE: It may take some wiggling and prying to loosen this assembly, because the rubber seal (5) will have taken a set.*
10. Inspect the cord seal (5) for damage.

G. When removing motor rotor (14)...

1. Complete sections A, B, C, D and E. Section C and F may or may not be completed first. If the cord and cover assembly has been removed, two 3/8" eye bolts will be required when lifting the motor housing and stator off the unit.
2. Place pump vertical on the work surface. The pump must be blocked or set back in pump housing to allow shaft to extend out the bottom.
3. Remove four screws (2) and lockwashers (3) between motor housing (12) and adapter (19).
4. Lift the motor housing and stator (12) up off the adapter (19), high enough to reach the moisture sensor wires (39) and unplug terminals from moisture sensors (17).
5. Finish lifting the motor housing (12) off the adapter (19). Be careful to lift the motor housing straight up, so as not to damage the stator windings or bearings.
6. Remove seal ring (18) from adapter (19) and inspect.
7. Remove bearing pre-load washer (40) from motor housing (12) and inspect.
8. Remove rotor assembly (14) from adapter (19).
9. Using a bearing puller, against the inner race, remove the lower bearing (16) and upper bearing (13) from the shaft. Replace the bearings if needed.

NOTE: Bearings should be cleaned with volatile mineral spirits and relubricated with proper lubricants immediately after cleaning. Never dry bearings with compressed air, and never spin un-lubricated bearings. See special instructions for direction of lower bearing installation.

H. Motor Stator...

NOTE: The motor housing and stator assembly removed in Section G number 5, is a factory assembled unit and must be replaced as such: it consists of the motor housing, the glued in stator, the through the wall electrical terminals for the power, and the moisture sensor wires.

I. Removing Sensor Studs...

1. Complete Section A, Section E #10, and Section G #5.
2. Unscrew moisture sensors (17) from the adapter (19).

ASSEMBLY PROCEDURES

Pumps are reassembled in reverse order of dissemble. The following suggestions are offered.

NOTE: While the pump is dismantled, all gaskets, seal rings and retaining rings should be checked for wear and deterioration. Replace all worn items. Ensure that all parts are thoroughly cleaned before assembly.

Assembly Procedures

A. Installing the sensor studs (17)...

1. Apply oil to threads of sensor studs (17).
2. Apply oil into threaded holes in adapter (19).
3. Screw sensor stud (17) into adapter (19) apply 34 in/lbs. of torque.

B. Assembly of rotor (14)...

1. Inspect rotor to see that the snap ring is in place and snapped in the groove.
This snap ring serves as a locator for the lower bearings.

NOTE: Before installing the bearing, wipe the bearing seats on the shaft clean and coat the seats with oil to prevent galling of the shaft as the bearings are pressed onto the shaft. A properly sized pressing sleeve should be used to install bearings, with pressure being applied to only the inner bearing race.

2. Install the lower ball bearing (16) and the upper ball bearing (13) on the rotor shaft (14). See lower angular contact bearing instruction page 6 for bearing orientation.
3. Set the adapter (19) on blocks to allow the rotor shaft to clear the work surface when installed.
4. Install the rotor/bearings assembly into the adapter housing (19). Make sure the lower bearing is seated in the bearing pocket.

C. Installing the motor housing/stator (12)...

NOTE: The motor housing/stator assembly is furnished from the factory as a glued in unit. The assembly will include the motor housing, the stator prewired to be installed through wall terminals (10) and moisture sensor wires (41).

1. Lightly oil and position the seal ring (18) around the pilot shoulder of the adapter (19).
2. Install the pre-load washer (38) in the upper bearing pocket of the housing/stator unit (12). The pre-load washer should be stretched a little to allow it to remain in the pocket when turned upside down.
3. With the rotor/adapter assembly in the vertical position suspend the motor housing/stator unit over it. Slowly lower the unit aligning the rotor and stator opening. Plug the moisture sensor wires (39) onto the sensors (17) at this time.
4. Tuck the moisture sensor wires away from the rotor while lowering the motor housing/stator unit into place on the adapter.
5. Secure the motor housing/stator (12) to the adapter (19) with four screws (2) and four lock washers (3). Torque screws to 175-195 in/lbs.

NOTE: The small arrow heads on housing flanges are to be aligned for proper orientation.

D. Installing cord and cover assembly...

NOTE: The cords will come from the factory as a cords and clamp assembly (6). The assembly consist of the power cord, the sensor cord, the wire terminals, the clamp and the potting compound between the cords and clamp.

1. Unroll the cords of the cord and clamp assembly (6) and slide the cord seal (5) down the cords to the clamp.
2. From the inside of the cover (4) place the cords of the assembly (6) through the holes and pull through the top.
3. Push the cord seal (5) into it's pocket inside the cover (4). Push the clamp (6) tight against the seal.
4. Apply thread locker compounds to the screws (8) and install into clamp along with lock washers (7). Using a cross pattern tighten the screws to the seal clamp evenly. Torque screws to 69-72 in/lbs.
5. Apply thread locker compound to ground screw and install ground wires to cover.
6. Lightly oil and install seal ring (9) on shoulder of cover (4).
7. Suspend the cord and cover assembly over the motor housing and make wiring connections per the proper wiring diagram.

NOTE: The power wiring goes to the numbered terminal, the moisture sensor to M1 and M2 and the thermosensor to T1 and T2.

8. Tuck the wires in the cover assembly as installing the cover into place.
9. Secure the cover (4) to the motor housing (12) with four screws (2) and four lock washers (3). Torque screws to 175-195 in-lbs.

NOTE: The small arrow heads on the castings are to be aligned for proper orientation.

E. Installation of rotary seals and seal retainer

▲ CAUTION Make sure all seal faces remain free of dirt particles.

Apply a light coat of oil to seal faces before installing.

1. Refer to rotary seal component placement diagram for relative positioning of seal parts.
2. Apply a coating of oil to the seal seat and the bore of the adapter (19), and using a nonmetallic sleeve, press the seat into position in the adapter.

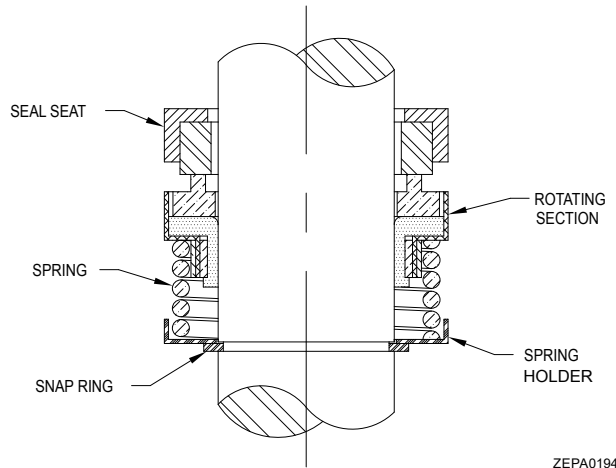

ZEPA0194

**ROTARY SEAL COMPONENT PLACEMENT
DIAGRAM**

3. Apply 80-90 weight gear oil to the shaft and to the inside diameter of the rotating section of rotary seal (20). Push the rotating section onto the shaft in a continuous motion until the seal faces meet.
4. Install the spring and spring holder over the shaft and seat against the rotating section. Compress the spring as necessary and install retaining ring (21) in the groove of the rotor shaft.
5. Lightly oil and install seal ring (18) on the seal retainer (23).
6. Press the seal retainer (23) into the adapter (19) and secure with the four socket head screws (22).
7. Install the seal seat and rotating section of the lower rotary seal assembly (24) into the seal retainer (23) in the same manner described in steps 2, 3, and 4 above.

F. Installing the impeller...

1. Install the proper number of impeller shims (25) on the shaft to give the face of the impeller (26). The proper running clearance from the pump housing (28). (See impeller clearance diagram on page 3.)
2. Install the square key (15) in the groove in the shaft.
3. Install the impeller (26).

G. Installing the pump housing (28)...

1. Lightly oil and install the seal ring (27) on the adapter (19).
2. Install the pump housing (28) on the adapter (19). Securing it with the four screws (2) and lock washers (3).
3. Torque screws to 175-195 in/lbs.

Note: Cutter plate and cutter can be replaced with new service parts or resurfaced by grinding. Resurfacing is accomplished by surface grinder both cutter plate and cutter to a 32 micro finish. Do not attempt grinding in the field. Send parts to a qualified machine shop or return to the factory for repair. The cutter plate and cutter shims are a matched set. Keep parts together. Measure disc before and after resurfacing, the cutter plate and cutter must be flat within 0.001". If the plate has been surface ground, it will be necessary to remove shims to compensate for the material removed

Assembly Procedures (continued)

form the plate plus any amount over 0.008" measured in the field before the cutter and plate were disassembled from the pump.

H. Installing the cutter plate (29)...

1. Carefully clean the area of pump housing (28) where the cutter plate (29) will be installed.
2. Install cleaned cutter plate (29) on the pump housing (28) with eight cutter plate screws (31).

Note: When the cutter plate is installed in the proper direction the eight radial relief slots will be facing out towards the cutter.

I. Installing the cutter (30)...

1. Install the proper amount of shims (25) on the shaft to obtain the proper running clearance between the cutter plate (29) and cutter (30).
2. Install the cutter (30) onto the shaft.
3. Install the screw (34), lockwasher (33) and flat washer (32) using thread locking compound and torquing to 175-195 in/lbs.

Note: Immobilize the cutter by placing a aluminum or brass rod in one of the holes in the cutter plate.

▲ CAUTION Do not chip or nick the cutter while using the rod to immobilize the cutter.

4. With the pump in the vertical position to remove end play, measure the running clearance between cutter (30) and cutter plate (29) using a feeler gauge. Repeat 1 thru 3 until .004" to .008" clearance is obtained. (See cutter clearance diagram on page 3).

Leak Test

(Before oiling pump) Perform a leak test on the pump seals by installing a regulated air supply into the holes (1/4" NPT access). The motor chamber, seal chamber and cover chamber must be checked. The pressure of the air supply should be set at approximately 9 PSI. Submerge the pump in clear water watching for small air bubbles around square ring seals, rotary seal, cord connection, and oil fill plugs.

NOTE: Make certain that the pump is placed in the water so that no areas are present that would trap air (such as the cavity around the lower rotary seal), not allowing the bubbles to rise to the water surface.

If it is not possible to leak test the pump using the submersion method, a regulated air supply with a (0-15 PSI) air gage can be installed in the fill holes. The pump to be pressurized and held at 9 PSI. After removing the air supply, the pressure should not drop more than 1/2 PSI in a 24 hour period.

J. Oiling and final assembly.

1. After leak testing has been completed, clean pipe plugs and reapply pipe dope or teflon tape. Install pipe plug (1) in cover (4).
2. With the pump laying on its side with the oil fill hole up fill the seal chamber cavity with an anti-wear non-detergent, rust inhibiting, paraffining oil of approximately 100 SUS. (See table below for acceptable type of oil.)

Refiner	Product Name
Arco	Duro 22 or 32
Exxon	Teresstic 22 or 32 or acceptable equal
Chevron	Clarity Hydraulic Aw ISO22 or ISO32

3. Clean pipe plugs and reapply pipe dope or teflon tape. Install pipeplug (1) in adapter (19).
4. While pump is on its side place approximately one quart of oil in motor housing. (Use the same oil as used in the seal cavity.)
5. Set the pump upright and finish filling the motor chamber with oil until it

runs back out the fill hole. With the oil running out the fill hole the oil will be at the proper level for the top bearing.

▲ WARNING Do not over fill.

6. Clean pipe plug and reapply pipe dope or teflon tape. Install pipe plug (1) in motor housing (12).

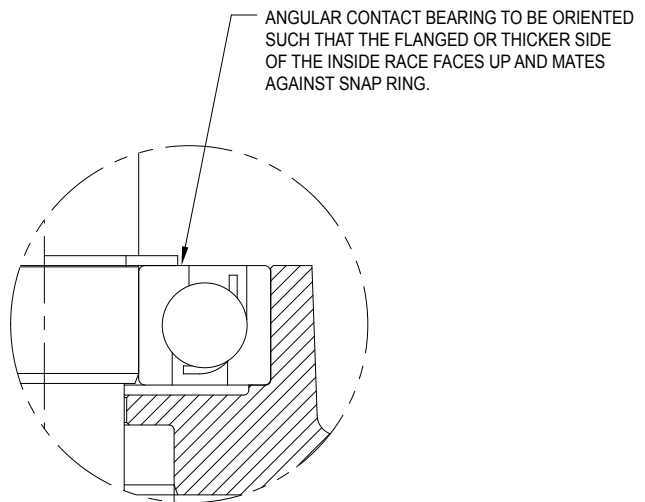

ZEPA0515

LOWER BEARING ORIENTATION

Wiring Diagrams

3 PHASE 71 SERIES GRINDER

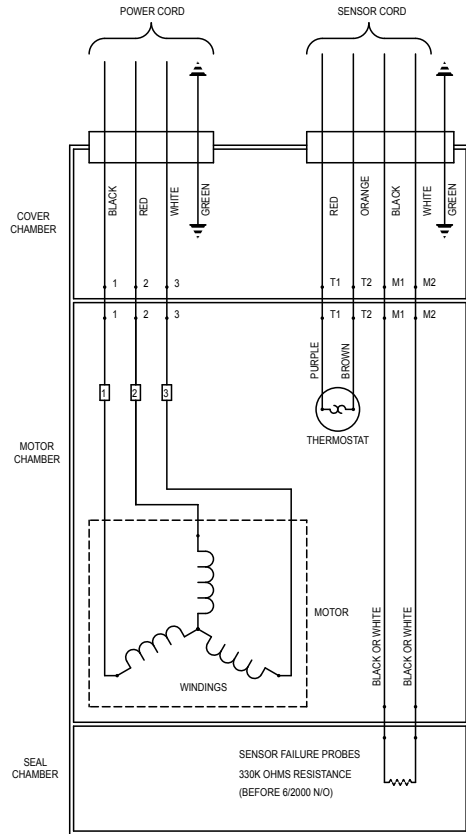

B00488

SINGLE PHASE 71 SERIES GRINDER

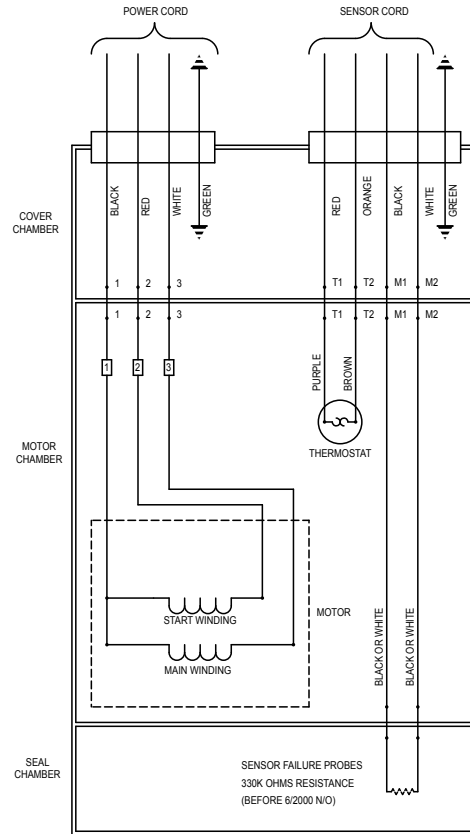

B00487

WIRING COMPONENT LAYOUT SINGLE PHASE 71 SERIES GRINDER

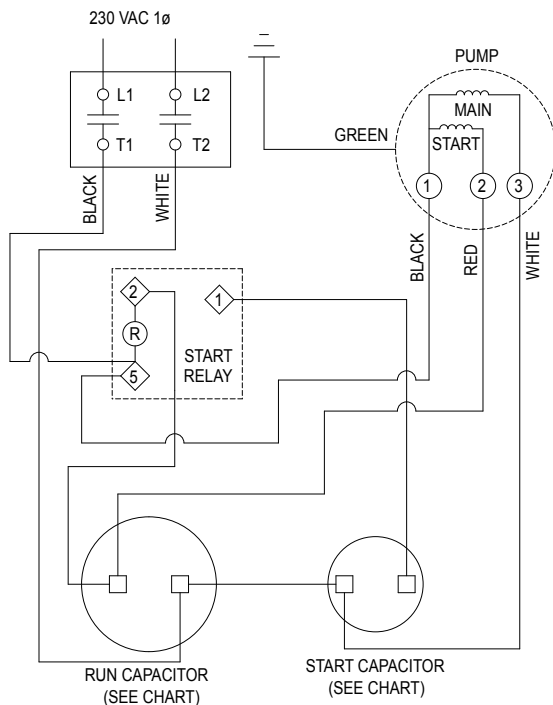

MODELS	START CAP.	RUN CAP.
7110/7111	270-324UF 250V	50UF 370V

ZEPA0537

START KITS AND COMPONENTS FOR SINGLE PHASE 71 SERIES GRINDER

PART#	DESCRIPTION
10-1011	KIT, STARTER MODELS 7110, 7111
012869	CAPACITOR, 50UF / 370 VAC
015155	RELAY, GE 3ARR22J10A2
012870	CAPACITOR, 270-324UF/220-250V

Service Checklist & Trouble Shooting



▲ WARNING ELECTRICAL PRECAUTIONS Before servicing a pump, always shut off the main power breaker to the panel and then disconnect the pump - making sure you are wearing insulated protective sole shoes and are not standing in water. Under flooded conditions, contact your local electric company or a qualified licensed electrician for disconnecting electrical service prior to pump removal.

▲ WARNING Submersible pumps contain oils which become pressurized and hot under operating conditions - allow 2½ hours after disconnecting before attempting service.

CONDITION

A. Pump will not start or run.

Steps	Check Voltage At	If No Voltage	If Voltage
No. 1	Line terminals in pump's control panel L1 - L2 - L3 (3 Phase)	Check Disconnect switch, line fuse, and/or circuit breakers in power supply circuit.	Proceed to No. 2
No. 2	Pump motor terminals in pump's control panel T1 - T2 - T3	Check for control circuit voltage. Check out magnetic starter contacts, thermal overloads, and float switches	Check starting relay and capacitor (1 phase units). Check pump for ground and binding impeller

COMMON CAUSES

B. Motor overheats and trips overload or blows fuse.

- Incorrect voltage
- Unbalanced power source
- Incorrect motor rotation
- Negative or low head
- Excessive water temperature
- Impeller or seal mechanically bound
- Defective capacitor or relay
- Motor shorted
- Lost one line in a three phase unit

C. Pumps starts and stops too often.

- Check valve stuck open
- Level controls out of adjustment
- Temperature sensor tripping
- Thermal overload switch out of adjustment or defective
- Pit too small

D. Pump will not shut off.

- Debris under float switch
- Float travel obstructed
- Defective or damaged float switch
- Magnetic starter contacts shorted
- Air lock - check vent hole

E. Pump operates but delivers little or no water.

- Check for plugged pump housing, discharge pipe or sticking check valve
- Vent hole clogged or not drilled
- Discharge head exceeds pumps capacity
- Low or incorrect voltage
- Incorrect motor rotation
- Defective capacitor

F. Drop in head and/or capacity after a period or use.

- Increased pipe friction
- Clogged line or check valve
- Abrasive material & chemical, deteriorated impeller and pump housing

If the above check list does not uncover the problem, consult the factory - Do not attempt to service or otherwise disassemble pump.