

PUMP INFORMATION

- TYPE: DEWATERING
 GRINDER
 SOLIDS HANDLING

PUMP MODEL _____
 _____ GPM TDH
 _____ DISCHARGE
 _____ HP RPM
 _____ AMPS (FLA)
 _____ VOLTS _____ PHASE _____ HZ

INSTALLATION

- FACTORY PRE-PACKAGED
 FIELD ASSEMBLED

* DISCHARGE PIPING, FITTINGS & RAILS
 SUPPLIED BY OTHERS IF
 FIELD ASSEMBLED

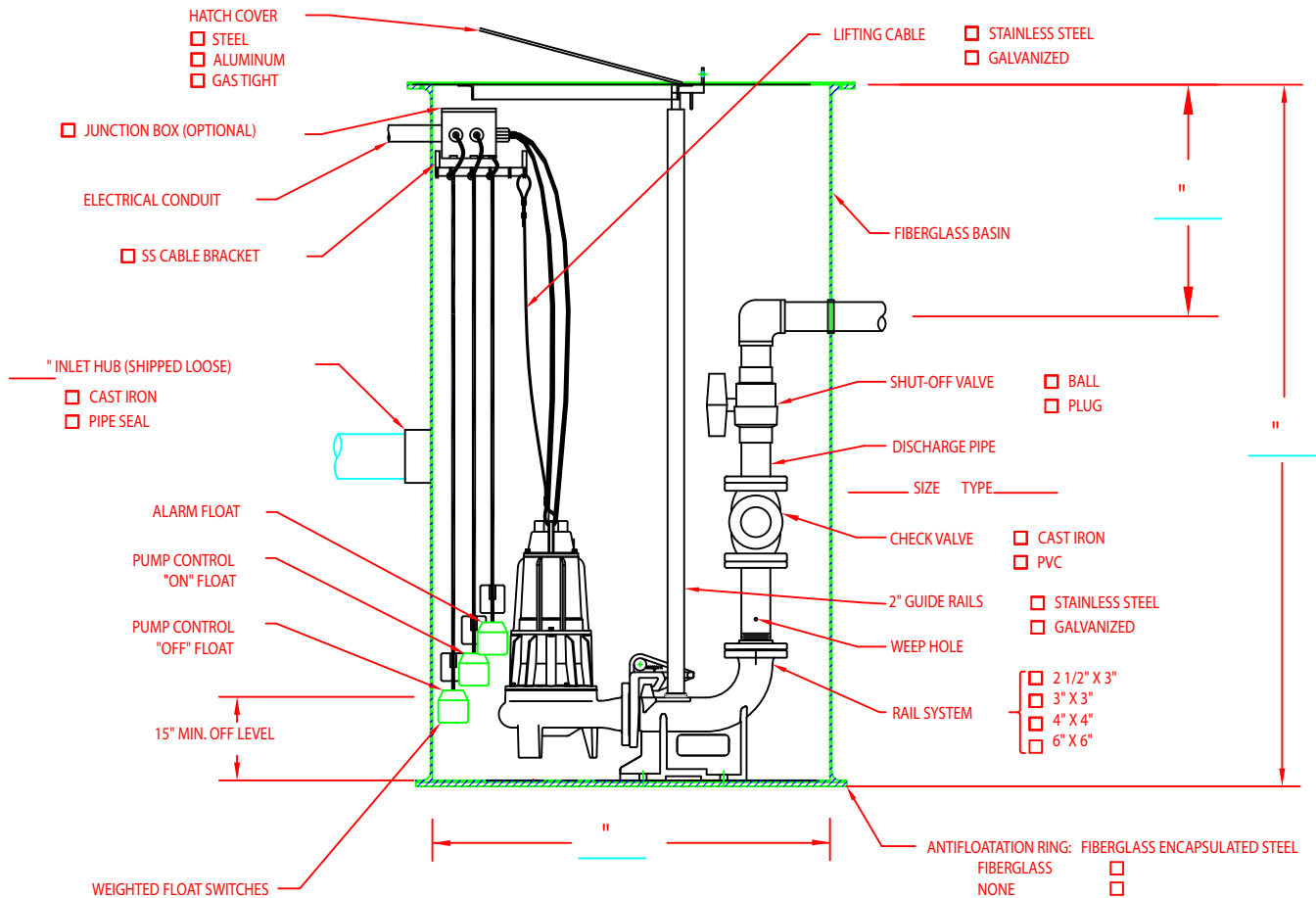
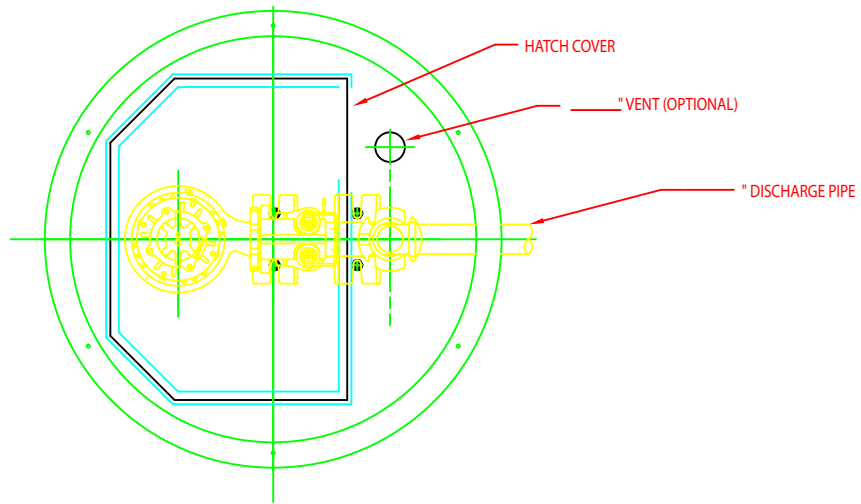

THE INFORMATION ON THESE DRAWINGS OR WEB PAGES IS MADE AVAILABLE FOR YOUR USE. HOWEVER, YOU USE THIS INFORMATION AT YOUR OWN RISK. WE BELIEVE THE INFORMATION TO BE CORRECT AND ACCURATE AT THE TIME OF ISSUE. ZOELLER COMPANY ASSUMES NO LIABILITY, EXPRESSED OR IMPLIED, RESULTING IN YOUR ACCESSING OR USING THIS INFORMATION. DUE TO CHANGES AND/OR DOWNLOAD PROBLEMS, IT IS YOUR RESPONSIBILITY AND YOU AGREE TO BE SOLELY RESPONSIBLE TO VERIFY THAT THE INFORMATION IS CORRECT AND ACCURATE FOR YOUR PURPOSES.

SK2426