

Product information presented here reflects conditions at time of publication. Consult factory regarding discrepancies or inconsistencies.



MAIL TO: P.O. BOX 16347 • Louisville, KY 40256-0347
SHIP TO: 3649 Cane Run Road • Louisville, KY 40211-1961
(502) 778-2731 • 1 (800) 928-PUMP • FAX (502) 774-3624

Visit our website:
zoellerengineered.com



6932 COVER MOUNTED REPLACEMENT ASSEMBLY FOR PROGRESSING CAVITY GRINDERS

INSTALLATION INSTRUCTIONS

PREINSTALLATION CHECKLIST

1. Inspect your pump assembly. Occasionally, products are damaged during shipment. If the unit is damaged, contact your Representative before using.
2. Carefully read the literature provided to familiarize you with specific details regarding installation and use. These materials should be retained for future reference.
3. Check to be sure your power source is capable of handling the 200 or 230 Volt, 1 Phase power requirements of the motor, as indicated on the pump name plate and literature.
4. Make sure the pump electrical supply circuit is equipped with fuses or circuit breakers of proper capacity. A separate branch circuit is recommended, sized according to the "National Electrical Code" for the current shown on the pump name plate and literature.
5. See CAUTIONS & WARNINGS on ZM2607: MODEL 7020 & 7021 OWNER'S MANUAL.

TYPICAL REPLACEMENT INSTALLATION

1. Electrical wiring and enclosures must be in accordance with the "National Electrical Code" and any other applicable state and electrical requirements.
2. **▲ WARNING** ELECTRICAL PRECAUTION: Before servicing a pump always shut off the main power breaker, making sure you are wearing insulated protective sole shoes and are not standing in water. Under flooded conditions, contact your local electrical company or a qualified licensed electrician for disconnecting electrical service prior to pump removal. Refer to the original installation/service manual for any precautions that need to be obeyed, i.e. pump may have more than one electrical supply connection.

OLD PUMP REMOVAL:

1. Shut pump power off.
2. Unlock and raise hinged riser lid.
3. Open the electrical quick disconnect, separating the male and female power plugs. Bag the female side to keep dry.
4. Close quarter turn ball valve on pump discharge pipe, next to the gooseneck connectors.
5. Loosen the captive 5/16" bolts that retain pump assembly cover.
6. Attach a lifting rope or cable to the choker located on the cover.
7. Safely lift pump assembly from basin.

NEW PUMP INSTALLATION, COVER MOUNTED TYPE:

1. Prepare your Zoeller grinder pump assembly for installation by removing all packing materials including the white nylon ties that are holding the alarm float and pump control float to the suspension pipe and discharge pipe.
2. Adjust gooseneck outlet pipe (see Fig. 1) and tighten compression nut with distance being verified by lowering pump assembly into basin and ensuring that the suspension plate of the pump assembly seats securely on the protruded surface located at the basin opening, and the quarter turn ball valve handle remains operable. Height is easily adjusted up or down to accommodate any field variances.
3. Alarm and pump control switches are set at the factory. The pump control switch is set to give a pumping range of 7". The alarm is set to turn "on" before the inlet.
NOTE: Float switches must be positioned so that they will be free of any object in the basin and its sidewalls. They are factory set but should be inspected during installation, insuring that the floats will not hang up inside the basin.
4. Apply foam gasket to bottom side of pump plate.
5. Clean off the protruded surface area where the suspension plate sits.
6. Attach lifting rope to the stainless steel choker on the pump plate.
7. Lower pump assembly into basin being sure to line up plate positioning ears (located 90 degrees from gooseneck outlet pipe) in basin.
8. (Inspect EQD gasket, install new gasket if any damage is present) Attach quick electrical disconnect plugs and secure screws, 25 in-lbs.
9. Open quarter turn ball valve by rotating it over gooseneck outlet pipe.
10. Pump assembly will seat in positioning ears and gooseneck outlet will engage discharge assembly (see Fig. 1).
11. Tighten bolts (supplied) and washers (supplied) to plate.

NEW PUMP OPERATION: Caution: Do not run pump dry

1. Turn control panel power on and check panel functionality.
2. Replace control panel if not functioning correctly. Consult factory.
3. Fill basin and allow unit to cycle (on-off). Time the pump-out cycle. The cycle should be at or less than the recorded cycle time.
4. Close the hinged riser lid and lock.

Installation is now complete. See Fig. 2A and 2B for wiring diagram.

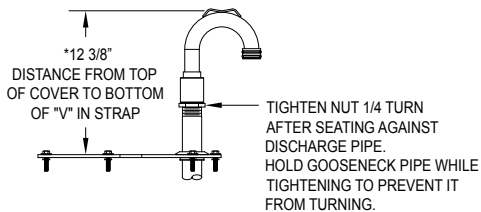

* DISTANCE TO BE VERIFIED BY LOWERING PUMP ASSEMBLY INTO BASIN AND ENSURING THAT THE SUSPENSION PLATE OF THE PUMP ASSEMBLY SEATS AGAINST THE PROTRUDED SURFACE AND THE BALL VALVE HANDLE REMAINS OPERABLE. HEIGHT IS EASILY ADJUSTED UP/DOWN TO ACCOMMODATE ANY FIELD VARIANCES.

SK2682

**Fig. 1
RWD or RWH
Cover Mounted Style**

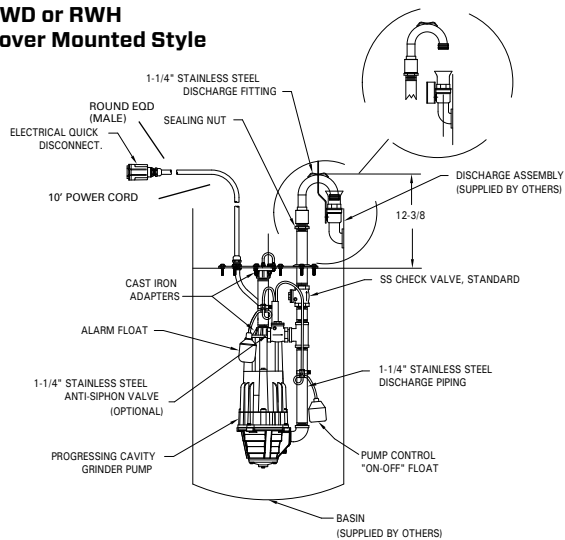

SK3226

Fig. 2A -RWD or RWH

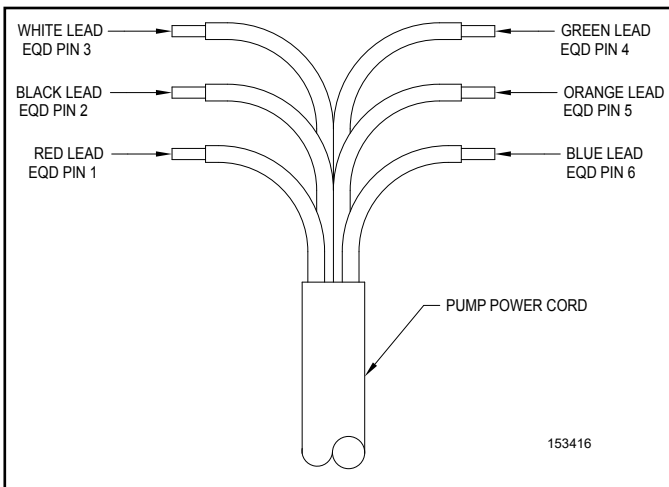

153416

OPTIONAL ANTI-SIPHON KIT (10-4828)

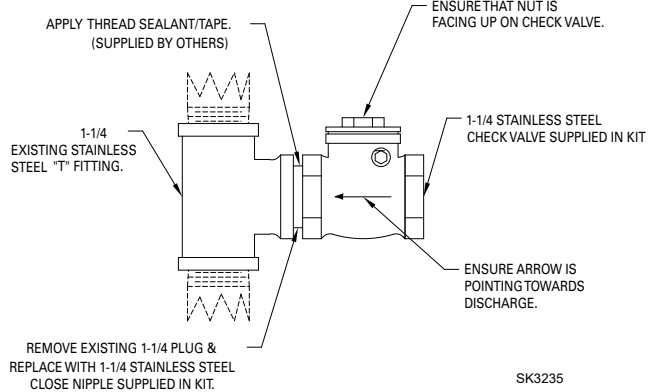

SK3235

Fig. 2B - RWD or RWH

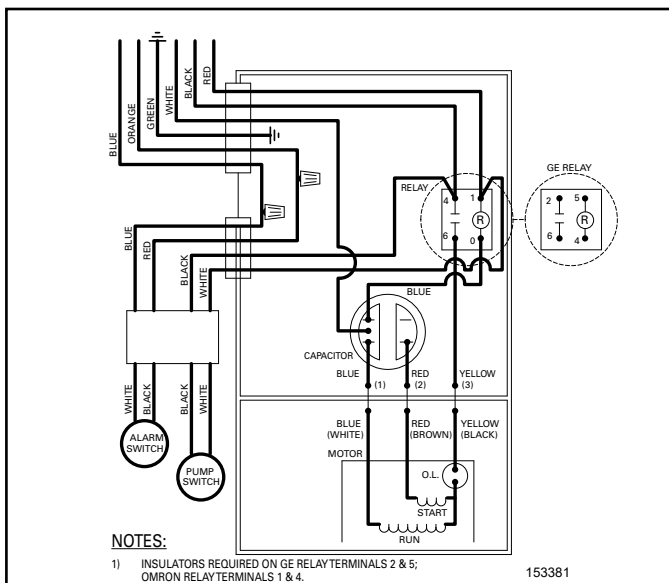

153381

OPTIONAL EQD ADAPTER

This item is used to adapt an existing rectangular EQD to a new 6932 replacement system having a round connector. The rectangular EQD is available as an option on our current 6932 replacement system.



Round

Part No. 10-4824

Rectangular

