

Trusted. Tested. Tough.®

Product information presented here reflects conditions at time of publication. Consult factory regarding discrepancies or inconsistencies.



SECTION: Z3.50.100

ZM2970

1021

Supersedes

0818

MAIL TO: P.O. BOX 16347 • Louisville, KY 40256-0347
SHIP TO: 3649 Cane Run Road • Louisville, KY 40211-1961
(502) 778-2731 • 1 (800) 928-PUMP • FAX (502) 774-3624

Visit our website:
zoellerengineered.com



X64 HD HAZARDOUS LOCATION SERIES

CLASS I, DIVISION 1, GROUP C & D

PRODUCT FEATURES

25 - 60 BHP

4" & 6" Flanged Discharge Units

Models: X6424 - X6428



Tested to CSA Standard
C22.2 No. 108



APPLICATIONS

- Engineered Lift Stations
- Storm Water Removal
- All Wastewater Transfer
- Industrial Wastewater

SPECIFICATIONS

PUMP:

- Discharge size - 4" & 6" horizontal flanged
- Solids - 4" - 3-1/8" spherical capability
6" - 4" spherical capability
- Seals - Dual mechanical; carbon/rotary, ceramic/stationary, Buna-N elastomers
- Seal leak probes
- Construction - cast iron ASTM A-48, Class 30, 30,000# tensile strength
- Attaching hardware - 316 stainless steel
- "O" ring elastomers - Buna-N
- Dual 2 vane enclosed ductile iron impeller
- Pump housing with bronze wear ring (4" only) - U-Cup Seal (6")
- Optional:
 - Trimmed Impeller
 - Additional cord length ____ ft.
 - Tungsten carbide shaft seal(s)

MOTOR:

- Class I, Division 1, Hazardous Locations
- UL and CSA listed motor
- 3 Phase - 1725 RPM, 230 volt: 25 & 30 BHP, 460/ 575V: 25-60 BHP
- Stator - Class F insulation and lead wires
- Thermal sensor protection
- Housing - cast iron, air filled
- Ball bearings - Dual high carbon chromium steel
- Power and sensor cord length - 25'
- Inverter duty capable (Class I, Division 1, Group D, 1.0 SF, T2A temp code on inverter power)

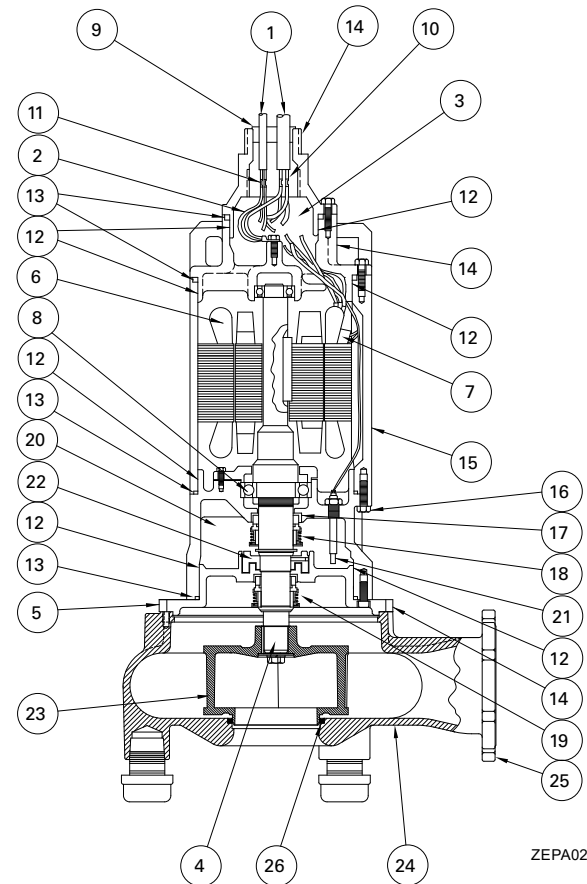

ZEPA0273A

FEATURES

EASY INSTALLATION: Motor is normally supplied with twenty-five feet of multi conductor, power cable and control cable (1), with ground wire (2) as standard. Alternate cable lengths are available. Large chamber (3) speeds cable connection. Close coupling to pump eliminates alignment problems. Impeller mounts on motor stainless steel shaft extension (4), which also serves as pump shaft. Pump and motor assembly can be lowered into position as a single, compact unit. Mounting flange (5) fits pump housing. Small overall motor dimensions, through use of NEMA-T frame electrics, reduce space requirements.

Long lasting internal components - Class F insulation system (6) rated for continuous duty when submerged in 40 °C liquids with a 1.15 service factor. Thermal protection (7) standard on all motors. Conservatively rated locked antifriction ball bearings (8) for thrust loads.

Complete environmental protection - Buna-N grommets (9) epoxy sealed leads (10), and butt spliced connectors (11) keep liquid from entering the top of the motor. All mating frame fits (12) have rabbet

joints with a large overlap, as well as O-ring seals (13). End brackets (14) and frame (15) are corrosion resistant cast iron. Smooth frame design unobstructed by ribs eliminates clogging of frame and makes cleaning easy. Hardware (16) is stainless steel. Seal faces (17) are carbon and ceramic. Inner (18) and outer seals (19) provide complete protection for motor internals. Both seals have stainless steel and Buna-N components. Sealed oil-filled chamber (20) permits maximum combined depth and internal pump pressures of 100 psi. Two moisture sensing probes (21) warn of impending seal failure. The labyrinth slinger (22) provides Class I Groups C and D enclosure and acts as a protective slinger for inner seal.

Balanced 2 vane ductile iron enclosed impeller (23) with pump out vanes for seal protection that is keyed and bolted to the shaft. The concentric case (24) reduces radial loading for longer bearing and seal life and comes with a 4" or 6" horizontal discharge (25). The 4" pump housing has a bronze wear ring while the 6" pump housing has a Buna-N U-cup seal (26). The unit is protected with a 2-part corrosion resistant epoxy coating.