

Trusted. Tested. Tough.®

Product information presented here reflects conditions at time of publication. Consult factory regarding discrepancies or inconsistencies.

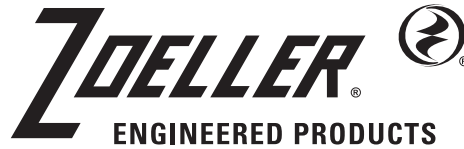

SECTION: Z2.30.100
ZM2968
0721
Supersedes
0121

MAIL TO: P.O. BOX 16347 • Louisville, KY 40256-0347
SHIP TO: 3649 Cane Run Road • Louisville, KY 40211-1961
(502) 778-2731 • 1 (800) 928-PUMP • FAX (502) 774-3624

Visit our website:
zoellerengineered.com



64 HD SERIES

PRODUCT FEATURES

25 - 60 BHP

4" & 6" Flanged Discharge Units

Models: 6424 - 6428



Certified to CSA
Standard C22.2 No 108



APPLICATIONS

- Engineered Lift Stations.
- Storm Water Removal.
- Wastewater Transfer.
- Industrial Wastewater.

SPECIFICATIONS

PUMP:

- Discharge size - 4" & 6" horizontal flanged
- Solids - 4" - 3-1/8" spherical capability
- Solids - 6" - 4" spherical capability
- Seals - Dual mechanical; carbon/rotary, ceramic/stationary, Buna-N elastomers
- Seal leak probes
- Pump housing and cover - Cast Iron ASTM A-48, Class 30, 30,000# tensile strength
- Motor housing and attaching hardware - 304 stainless steel
- "O" ring elastomers - Buna-N
- Ductile iron impeller - Dual vane enclosed design
- Pump housing wear ring (4" only) - U-Cup Seal (6")
- Optional:
 - Silicon Carbide seals
 - Viton O-rings
 - Trimmed Impeller
 - Additional cord length ____ ft.
 - Rail System
 - Vortex Impeller
 - High temperature construction (25 & 30 HP only, not CSA listed)

MOTOR:

- 3 Phase - 230 Volt, 1750 RPM: 25 & 30 BHP; 460 & 575 Volt, 1750 RPM: 25 to 60 BHP
- Stator - Class F insulation and lead wires Nema B design
- Thermal sensor protection
- Housing - Stainless Steel, oil filled
- Ball bearings - Dual high carbon chromium steel
- Power cable length - 25'
- Optional:
 - Inverter duty motor, 25-50 BHP, 230 & 460 volt only (not CSA listed)

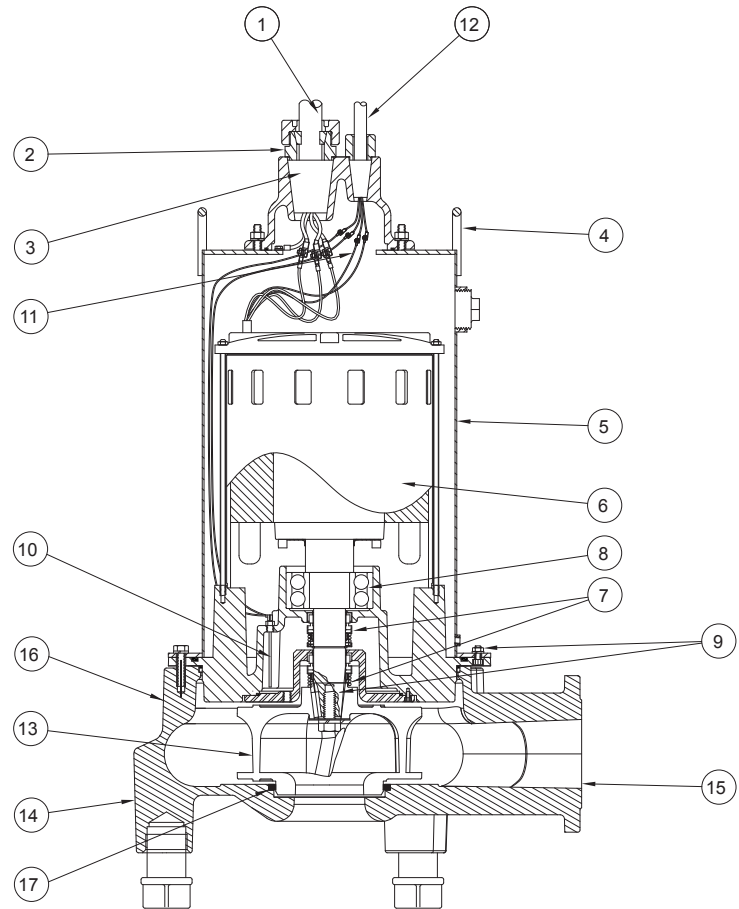

SK3140

FEATURES:

1. 25' of extra heavy duty power cable.
2. Heavy wall conduit threads and strain relief grommet for cable protection.
3. Protected cable entrance. The compression grommet allows for field replacement of the cable and each conductor is individually sealed to eliminate cord wicking of liquids.
4. Lifting lugs integral part of housing.
5. Oil-filled stainless steel motor housing assures uniform heat distribution, lubricates bearings, and conducts heat for cooler running.
6. Heavy duty motor features ball bearing construction. Class F motor insulation is double dipped and baked. End connections and lead wires are Class F. At maximum load, winding temperature will not exceed 250 °F (155 °C) with motor housing not submerged.
7. Tandem seals. Carbon/rotating, ceramic/stationary, and Buna-N elastomers.
8. Upper and lower high carbon chromium steel ball bearings.
9. Stainless steel shaft and hardware resists corrosion.
10. Seal leak detector probes.
11. Thermal sensor protection.
12. 25' sensor cable.
13. Balanced ductile iron 2-vane closed impeller with top & bottom pump out vanes for seal protection keyed and bolted to shaft.
14. Concentric pump housing reduces radial loading for longer bearing and seal life.
15. 4" or 6" flanged horizontal ANSI B16.1 Class 125 discharge.
16. Cast iron parts protected with a powder coated epoxy coating.
17. Wear ring (4" discharge only)- U-Cup Seal (6").