

NOTICE TO INSTALLER: Instructions must remain with installation.

SECTION: Z4.20.140

Trusted. Tested. Tough.®

ZM1789

0321

Supersedes

1117

Product information presented here reflects conditions at time of publication. Consult factory regarding discrepancies or inconsistencies.



MAIL TO: P.O. BOX 16347 • Louisville, KY 40256-0347
SHIP TO: 3649 Cane Run Road • Louisville, KY 40211-1961
(502) 778-2731 • 1 (800) 928-PUMP • FAX (502) 774-3624

Visit our website:
zoellerengineered.com

Register your
Zoeller Engineered Product
on our website:
<http://reg.zoellerengprod.com/>

OWNER'S MANUAL



71 SERIES SUBMERSIBLE GRINDER UNITS

Congratulations on the purchase of the Zoeller 71 Series submersible grinder pump. Zoeller Grinder Pumps are designed for grinding and pumping sanitary sewage from submersible lift stations. The pump is intended to grind and pump reasonable quantities of disposable diapers, sanitary napkins, paper towels, rubber materials, plastics, cigarette butts and other items normally found in sanitary sewage applications. Since 1939, the name Zoeller has represented the standard for submersible dewatering and sewage pumps. The same high quality workmanship and easy maintenance design has been incorporated into this line of heavy-duty submersible grinder pumps. This Zoeller pump will provide years of trouble-free service when installed according to the manufacturers' recommendations.

This manual incorporates the installation, operation, maintenance, and service instructions into one document to aid in the ownership of a Zoeller submersible wastewater product. Please read and review this manual before installing the product. Follow the steps and procedures listed on ZM1074 for a proper start-up. Many items contained within, when followed correctly, will not only ensure a long and problem-free life for the pump, but also save time and money during installation. Reference ZM1788 for repair manual on 71 Series Grinder Pumps. Should further assistance be necessary please call our Product Support Department at 1-800-928-PUMP (7867).

TABLE OF CONTENTS

- Safety Instructions 1
- Limited Warranty 2
- Preinstallation Information..... 3
- Electrical Data 3
- Typical Sewage Installation 4
- Pump Wiring Instructions..... 5-6
- Operation..... 7
- Maintenance 7
- Service Checklist 8

SAFETY INSTRUCTIONS

TO AVOID SERIOUS OR FATAL PERSONAL INJURY OR MAJOR PROPERTY DAMAGE, READ AND FOLLOW ALL SAFETY INSTRUCTIONS IN THIS MANUAL AND ON THE PUMP.

THIS MANUAL IS INTENDED TO ASSIST IN THE INSTALLATION AND OPERATION OF THIS UNIT AND MUST BE KEPT WITH THE PUMP.



This is a **SAFETY ALERT SYMBOL**. When you see this symbol on the pump or in the manual, look for one of the following signal words and be alert to the potential for personal injury or property damage.

- ▲ DANGER** Warns of hazards that **WILL** cause serious personal injury, death or major property damage.
- ▲ WARNING** Warns of hazards that **CAN** cause serious personal injury, death or major property damage.
- ▲ CAUTION** Warns of hazards that **CAN** cause personal injury or property damage.
- ▲ NOTICE** INDICATES SPECIAL INSTRUCTIONS WHICH ARE VERY IMPORTANT AND MUST BE FOLLOWED.

THOROUGHLY REVIEW ALL INSTRUCTIONS AND WARNINGS PRIOR TO PERFORMING ANY WORK ON THIS PUMP.

MAINTAIN ALL SAFETY DECALS.

OWNER'S INFORMATION

Model Number: _____ Date Code: _____

Serial Number: Pump 1 _____ Pump 2 _____

Simplex Panel P/N _____

Duplex Rail System P/N _____

Job Name: _____

Distributor: _____

Sales Order Number: _____

Contractor: _____

Date of Installation: _____

System Readings During Operation: Voltage _____ Amps _____

REFER TO WARRANTY ON PAGE 2.

LIMITED WARRANTY

Zoeller Engineered Products warrants its 71 Series of submersible pumps to the original owner to be free from defects in workmanship and materials under the following conditions and limitations. The owner will pay the applicable percentage of the list price of the following parts in effect at time of replacement.

Conditions

1. Approval of the installation and start-up of the equipment by the authorized Zoeller representative.
2. Pump removal, reinstallation and transportation charges shall be borne by the owner.
3. Warranty repairs shall be conducted by an Authorized Warranty Service Center (ASWC) only. Any pump repair labor charges done after the warranty period will be borne by the owner.
4. Hazardous Location Series pumps must be serviced at an approved service station or returned to the factory.
5. Controls and accessories warranty (See specific warranty below).

STANDARD WARRANTY

Standard warranty shall be 18 months from date of manufacture, 12 months from date of installation or 12 months from the date of start-up with a start-up report on file with Zoeller. Failure to have this start-up report on file with Zoeller will void this warranty.

*MUNICIPAL SEWAGE PERMANENT INSTALLATION

Five Year (10,000 hr) Months After Shipment - Limited Warranty

MONTHS HOURS	0-18 0-3,000	19-30 3,000-5,000	30-45 5,000-7,500	46-60 7,500-10,000
Rotor & Stator	0%	30%	50%	80%
Mechanical Seal	0%	30%	50%	75%
Impeller	0%	30%	50%	80%
Cutter Assy.	0%	30%	50%	80%
Ball Bearings	0%	50%	80%	100%
Pump Housing	0%	30%	50%	100%

Controls and accessories included for 18 months.

In instances where property damages are incurred as a result of an alleged product failure, the property owner must retain possession of the product for investigation purpose.

LIMITATIONS

Manufacturer warrants, to the purchaser and subsequent owner during the warranty period, every new product to be free from defects in material and workmanship under normal use and service, when properly used and maintained, for a period of one year from date of purchase by the end user, or 18 months from date of original manufacture of the product, whichever comes first. Parts that fail within the warranty period, one year from date of purchase by the end user, or 18 months from the date of original manufacture of the product, whichever comes first, that inspections determine to be defective in material or workmanship, will be repaired, replaced or remanufactured at Manufacturer's option, provided however, that by so doing we will not be obligated to replace an entire assembly, the entire mechanism or the complete unit. No allowance will be made for shipping charges, damages, labor or other charges that may occur due to product failure, repair or replacement.

This warranty does not apply to and there shall be no warranty for any material or product that has been disassembled without prior approval of Manufacturer, subjected to misuse, misapplication, neglect, alteration, accident or uncontrollable act of nature; that has not been installed, operated or maintained in accordance with Manufacturer's installation instructions; that has been exposed to outside substances including but not limited to the following: sand, gravel, cement, mud, tar, hydrocarbons, hydrocarbon derivatives (oil, gasoline, solvents, etc.), or other abrasive or corrosive substances, wash towels or feminine sanitary products, etc.

in all applications other than in raw sewage pumping applications. The warranty set out in the paragraph above is in lieu of all other warranties expressed or implied; and we do not authorize any representative or other person to assume for us any other liability in connection with our products.

Contact Manufacturer at, 3649 Cane Run Road, Louisville, Kentucky 40211, Attention: Customer Support Department to obtain any needed repair or replacement of part(s) or additional information pertaining to our warranty.

MANUFACTURER EXPRESSLY DISCLAIMS LIABILITY FOR SPECIAL, CONSEQUENTIAL OR INCIDENTAL DAMAGES OR BREACH OF EXPRESSED OR IMPLIED WARRANTY; AND ANY IMPLIED WARRANTY OF FITNESS FOR A PARTICULAR PURPOSE AND OF MERCHANTABILITY SHALL BE LIMITED TO THE DURATION OF THE EXPRESSED WARRANTY.

Some states do not allow limitations on the duration of an implied warranty, so the above limitation may not apply to you. Some states do not allow the exclusion or limitation of incidental or consequential damages, so the above limitation or exclusion may not apply to you.

This warranty gives you specific legal rights and you may also have other rights which vary from state to state.

RECOMMENDED LIMITS OF APPLICATION

These recommended application limits are for pump stations pumping to a gravity main. Low-pressure pipe systems should be designed with a pump located at each house. For applications where a lift station would handle more than 60 homes, a solids handling type pump should be considered.

Model	HP	Simplex Station		Duplex Station	
		Homes	GPD	Homes	GPD
7110 High Head	3	2*	800	20	8,000
7111 High Head	5	2*	800	25	10,000
7112 High Head	7.5	2*	800	30	12,000
7110 Reversing	3	2*	800	30	12,000
7111 Reversing	5	2*	800	38	15,000
7112 Reversing	7.5	2*	800	45	18,000
7110 High Flow	3	2*	800	40	16,000
7111 High Flow	5	2*	800	50	20,000
7112 High Flow	7.5	2*	800	60	24,000

*Zoeller Company does not recommend a simplex station on anything over two homes in order to maintain continuous service during unusual conditions.

PREINSTALLATION INFORMATION

1. **Inspect your pump.** Occasionally, products are damaged during shipment. If the unit is damaged, contact your dealer before using. **DO NOT** remove the test plugs in the cover nor the motor housing.
2. **Carefully read the literature** provided to familiarize yourself with specific details regarding installation and use. These materials should be retained for future reference.



⚠ **WARNING**

SEE BELOW FOR LIST OF WARNINGS



SEE BELOW FOR LIST OF CAUTIONS

1. Do not lift, carry, or hang pump by the electrical cables. Damage to the electrical cables can cause shock, burns or death.
2. **Make sure there is a properly grounded connection available.** All pumps are furnished with provisions for proper grounding to help protect you against the possibility of electrical shock.
3. Make certain that the control box is within the reach of the pump's power supply cord. **DO NOT USE AN EXTENSION CORD.** Extension cords that are too long or too light do not deliver sufficient voltage to the pump motor. But, more important, they could present a safety hazard if the insulation were to become damaged or the connection end were to fall into the sump.
4. **Make sure the pump electrical supply circuit is equipped with fuses and disconnect or circuit breakers of proper capacity.** A separate branch circuit is recommended, sized according to the "National Electrical Code" for the current shown on the pump nameplate.
5. Risk of electric shock - These pumps have not been investigated for use in swimming pool areas.
6. According to the state of California (Prop 65), this product contains chemicals known to the state of California to cause cancer and birth defects or other reproductive harm.
7. **Do not attempt to turn cutter rotor located on bottom of the unit with fingers.** Use the appropriately sized wrench when checking or removing the cutter.
8. Risk of Explosion- Pump not to be installed in locations classified as hazardous by the NEC, ANSI/NFPA 70.
9. Risk of Electric Shock- Do not remove cord and strain relief. Do not connect conduit to pump.

1. Check to be sure your power source is capable of handling the voltage requirements of the motor, as indicated on the pump nameplate.
2. The float switches must be connected to an intrinsically safe circuit in the control panel. The installation of pumps using auxiliary variable level float switches is the responsibility of the installing party and care should be taken that the tethered float switch will not hang up on the pump apparatus or pit peculiarities and is secured so that the pump will shut off. It is recommended that rigid piping and fittings be used and the pit be 36" or larger in diameter.
3. **INFORMATION - VENT HOLE PURPOSE.** It is necessary that all submersible pumps capable of handling various sizes of solid waste be of the bottom intake design to reduce clogging and seal failures. If a check valve is incorporated in the installation, a vent hole (approx. 3/16") must be drilled in the discharge pipe below the check valve and pit cover to purge the unit of trapped air. Water stream will be visible from this hole during pump run periods. This vent hole should be checked periodically for clogging and cleaned as necessary. Trapped air is caused by agitation and/or a dry basin.
4. Water hammer creates momentary high pressure surges. These surges can cause severe damage to check valves and the piping system. Consideration for water hammer must be included in the piping system design. Reference ASPE Data Book, Chapter 2.33. Some systems may require external spring or lever weighted check valves or other engineered solutions.
5. Three phase pumps must be connected for proper rotation, which is counter-clockwise looking into impeller inlet. See page 5 for instructions for checking 3 phase rotation.
6. Grinder installations should be checked frequently for debris and/or buildup which may interfere with the "ON"/"OFF" cycles or the positions of variable level float control switches. For repair and service, other than cutter assembly maintenance, contact factory.
7. Care should be taken during the initial installation to be sure that adequate air supply is available whenever any person is in the basin. Always follow OSHA guidelines on confined space requirements.

NOTE: Pumps with the "UL" mark and pumps with the "US" mark are tested to UL Standard UL778. CSA Certified pumps are certified to CSA Standard C22.2 No. 108.

ELECTRICAL DATA												
Model	HP	Service Factor	RPM	Voltage	Phase	Hertz	Amps				KVA Code	Winding Resistance Line-to-Line
							Full Load	In Air	Shut Off	Locked Rotor		
E7110	3	1.2	3450	230	1	60	23.6	7.2	13.1	132	M	0.5/3.5
J7110	3	1.2	3450	200	3	60	17.3	5.7	10.7	66	J	0.8
F7110	3	1.2	3450	230	3	60	15.1	5.0	9.2	57	J	1.0
G7110	3	1.2	3450	460	3	60	7.5	2.5	4.6	28.5	J	4.0
BA7110	3	1.2	3450	575	3	60	6.0	2.3	3.1	25.2	K	6.6
E7111	5	1.2	3450	230	1	60	28.0	7.2	17.1	132	G	0.5/3.5
J7111	5	1.2	3450	200	3	60	20.7	7.6	14.4	94	E	0.44
F7111	5	1.2	3450	230	3	60	18.0	6.2	13.0	82	E	0.62
G7111	5	1.2	3450	460	3	60	9.0	3.1	6.5	41	E	2.4
BA7111	5	1.2	3450	575	3	60	7.2	2.9	5.2	36	J	3.4
J7112	7-1/2	1.2	3450	200	3	60	25.3	7.6	18.4	94	D	0.44
F7112	7-1/2	1.2	3450	230	3	60	22.0	6.2	16.0	82	D	0.62
G7112	7-1/2	1.2	3450	460	3	60	11.0	3.1	8.0	41	D	2.4
BA7112	7-1/2	1.2	3450	575	3	60	9.0	2.9	6.5	36	E	3.4

TYPICAL GRINDER PUMPING SYSTEM INSTALLATION

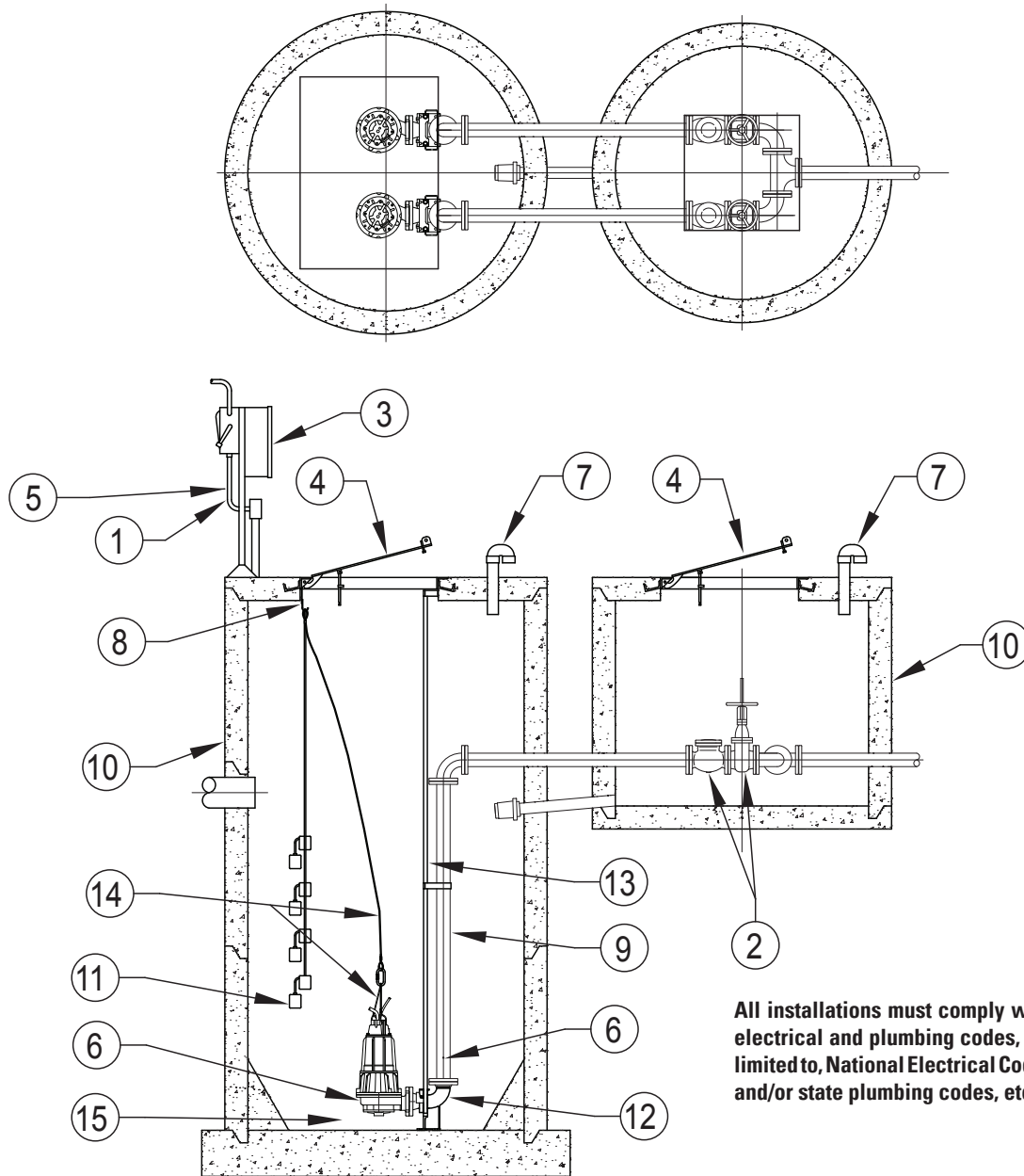

All installations must comply with all applicable electrical and plumbing codes, including, but not limited to, National Electrical Code, local, regional, and/or state plumbing codes, etc.

ZEPA0521

- (1) Electrical wiring and protection **must** be in accordance with the National Electrical Code, and any other applicable state and local electrical requirements.
- (2) Install proper full flow check and shut-off valve.
- (3) Install proper controls. (Outdoor panels **require** NEMA 3R or 4X enclosure)
- (4) All installations **require** a basin cover to prevent debris from falling into the basin and to prevent accidental injury.
- (5) Cords must be properly sealed to prevent moisture and gases from entering the control panel.
- (6) **When check valve is installed**, drill a 3/16" diameter hole in the discharge pipe below the check valve even with the top of the pump. **NOTE: The hole must be below the basin cover and cleaned periodically.** Also a vent hole is drilled in the pump housing. Be sure that this hole is cleared during any servicing.
- (7) Vent gases and odors to the atmosphere through vent pipe per Local and State codes.
- (8) Secure power cord to avoid entanglement with variable level float switch mechanism.
- (9) Do not reduce pump discharge pipe below 2" IPS size.
- (10) Basin **must** be in accordance with all applicable codes and specifications. Basin must be sized to allow a minimum 6-minute off time between starts.
- (11) Pump must be level and the tethered variable level float switches must be free and not hang up on pump or pit peculiarities.
- (12) **If a rail system is used**, discharge elbow **must** be firmly anchored to the bottom of basin. In fiberglass basin, the bottom will need to be reinforced if the discharge elbow is used.
- (13) **If a rail system is used**, the guide rails are 2" schedule 40 pipe for all flanged-discharge grinder pumps. Brass, stainless steel or galvanized steel is recommended.
- (14) Install ring and cable for lifting pump from pit.
- (15) Basin must be clean and free of debris after installation and before operation.

PUMP WIRING INSTRUCTIONS



- ▲ WARNING** Installation and checking of electrical circuits and hardware should be performed by a qualified licensed electrician.
- ▲ WARNING** “Risk of electrical shock” Do not remove power supply cord and strain relief or connect conduit directly to the pump.
- ▲ CAUTION** Power cords, sensor cords, and float cords all must be sealed to prevent gases from the basin entering the control panel.

INSTRUCTIONS FOR CHECKING ROTATION OF THREE PHASE UNITS

It is very important that these units be connected for proper rotation. Since no rotating parts are visible without removing the pump from the pit, the rotation on 3 phase units should be checked before installation into the pit as follows:

After the proper electrical connections are made, momentarily energize the pump observing the direction of kick back due to starting torque. The rotation is correct if the kick back is in the opposite direction of the rotation arrow. If the rotation is not correct, disconnect power and switch any two power leads. Turn power back on and retest for proper rotation.

SENSOR CABLE

The sensor cable is the smaller cable, which contains 5 wires. The red and orange wires connect to the thermal cut-out circuit and the black and white wires connect to the seal leak probes. The green wire is a ground connection. All 5 wires must terminate in the control panel.

The following should be noted:

- (1) The thermal sensors are normally closed and mounted adjacent to the motor windings. If internal temperatures exceed a maximum limit, the pump will deactivate when the red and orange wires are connected in series to the control coil of the motor starter circuit. The pump is able to restart once the motor cools down. Continued deactivation of this circuit requires the attention from maintenance personnel.
- (2) The black and white seal leak wires are connected to a 330K ohm moisture detection circuit. An indicator light will activate whenever water is present in the shaft seal cavity or cord cap assembly. Whenever the seal leak light is activated, indicating the entry of moisture into the pump, it should be removed and serviced in order to avoid damage to the motor. Moisture sensor circuit can be checked for continuity (complete circuit) with a (Volt-OHM-Meter). Set the VOM to read resistance and connect the VOM leads to the sensor cord black and white wires. The VOM should read approximately 330k Ohms. Resistance readings significantly lower indicates an entry of moisture into the pump. If VOM reading is open then a problem exists with moisture detection circuit.
- (3) The green wire shall be connected to a ground lug in the panel. Check resistance between the green ground conductor of the pump power cord and the sensor cord black and white wires. This resistance reading should indicate an open circuit. If VOM reading returns a reading other than open, then a problem exists with the sensor circuit wiring or cordage. If resistance readings show a problem with either test, then pump should be repaired by a Zoeller Authorized Service Station.

CONTROL PANELS

These pumps are nonautomatic and they require a control panel. A motor starter circuit, control circuit, and high-water alarm circuit within the panel are standard features. Enclosures rated for outdoor use and alternating relays are often required. Variable level float switches are the most common level sensing device. The following should be noted.

- (1) Single phase units require externally mounted capacitors and starting relays. Your control panel should have provisions for mounting these starting components.
- (2) The seal failure sensor and thermal sensor protection require that interfacing terminals and functions be incorporated into the panel.
- (3) All pumps require overload protection in panel. Use with approved motor control that matches motor input in full load amperes with overload element(s) selected or adjusted in accordance with control instructions.
- (4) Lightning arrestors, condensation heaters and elapsed-time meters are optional features that provide added protection.

POWER AND SENSOR CORD, LEAD IDENTIFICATION

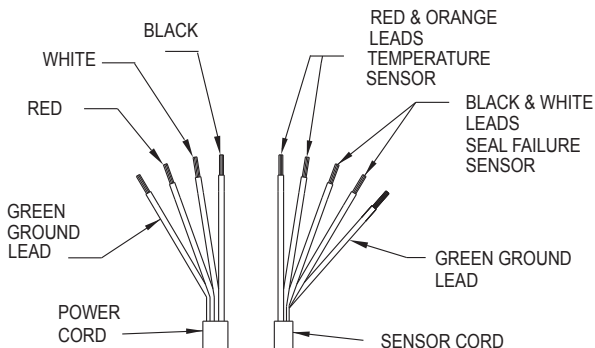

“71 SERIES GRINDER” FOUR CONDUCTOR AWG. POWER CORD SIZE

MODEL	HP	230/1 PH	200/3 PH	230/3 PH	460/3 PH	575/3 PH
7110	3	8 AWG.	12 AWG.	12 AWG.	12 AWG.	12 AWG.
7111	5	8 AWG.	8 AWG.	12 AWG.	12 AWG.	12 AWG.
7112	7.5	N/A	8 AWG.	8 AWG.	12 AWG.	12 AWG.
APPROXIMATE CORD DIAMETER PER GAUGE						
12/4 AWG.	.68"					
8/4 AWG.	.96"					
NOTE: SENSOR CORD 18/5 AWG. APPROXIMATELY .48" DIAMETER.						

ZEPA0039E

SINGLE PHASE INSTALLATION (7110 & 7111 ONLY)

All single phase models require start capacitor, run capacitor and relay in the circuit to start and operate properly. These components can be purchased separately or prewired in a Zoeller control panel. For components purchased separately use the diagram for installation and hookup.

Single phase models are nonautomatic. To operate automatically a control panel must be added to the power circuit. Follow the instructions provided with the panel.

WIRING DIAGRAM

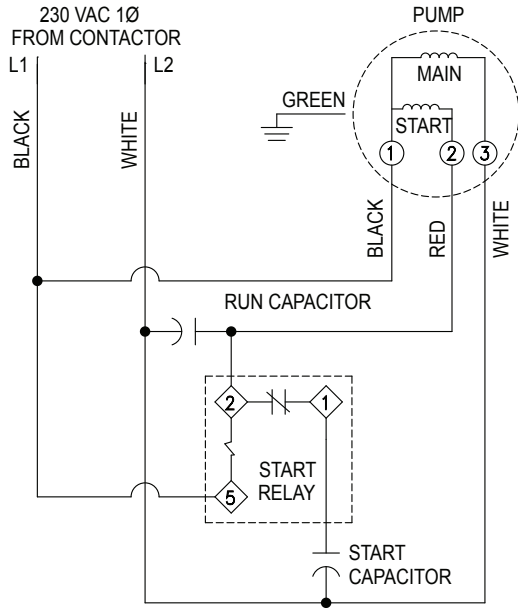

ZEPA0538

COMPONENT LAYOUT

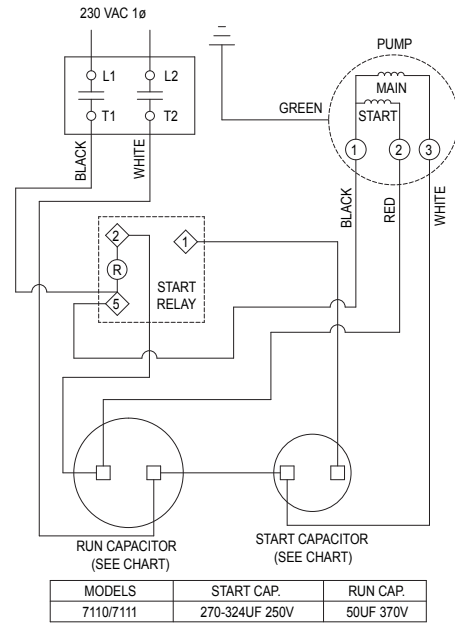

ZEPA0537C

THREE PHASE INSTALLATION

TYPICAL 3-PHASE WIRING DIAGRAM

Three phase pumps are nonautomatic. To operate automatically, a control panel is required. Follow the instructions provided with the panel to wire the system.

Before installing a pump, check the pump rotation to insure that wiring has been connected properly to power source, and that the green lead of power cord (See wiring diagram), is connected to a valid ground. Momentarily energize the pump, observing the directions of kick back due to starting torque. Rotation is correct if kick back is in the opposite direction of rotation arrow on the pump casing. If rotation is not correct, switching of any two power leads other than ground, should provide the proper rotation.

Refer to wiring diagram supplied with specific electrical control panel for correct electrical cable termination locations.

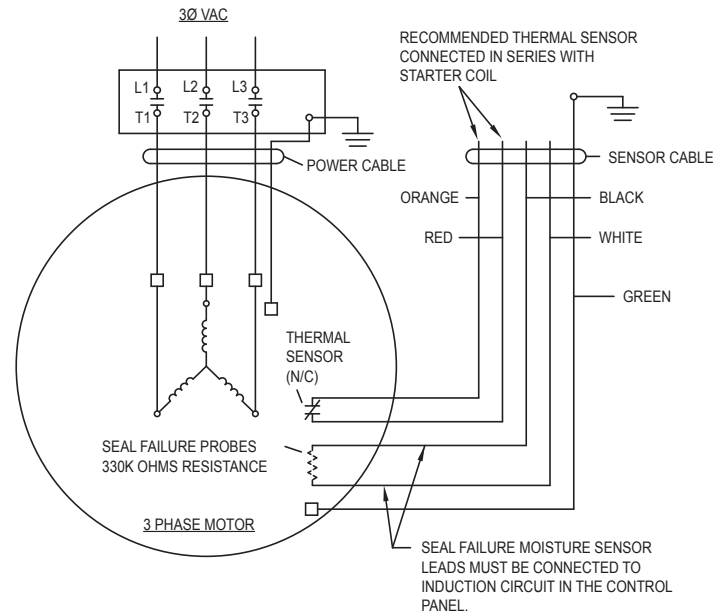

ZEPA0038E

Refer to Sensor Cable and Control Panel sections on page 5.

NOTE 1: Sensor cable includes 5 leads; 2 leads for thermal sensor, 2 leads for moisture sensor, and a green ground lead. Sensor wire colors are as shown.

OPERATION

GENERAL

Zoeller pumps are lubricated and tested at the factory prior to shipment and require minimum pre-start-up maintenance.

Maximum liquid temperature of a continuous operating pump liquid for this model pump must not exceed 104 °F (40 °C). For an extended service life, pumps should be totally submerged on long pumping cycles.

These units are not designed to handle liquids other than sewage. If pump is used in water contaminated with heavy, viscous, or abrasive materials, the warranty will be voided.

NAME PLATE DATA

The nameplate, located on the top of pump, indicates specific information about the construction of the pump. The model number, date code, and serial number should be recorded on the front page in the "Owner's Information" section of this manual.

SHORT TERM STORAGE

If pump is to be stored, the following is advised:

- Store pump inside whenever possible or cover with some type of protective covering.
- Tape or seal in plastic bag the terminal ends of wire leads.
- Pump is to be stored in an upright position. Seal leaks that occur in storage to a pump laying on its side will not be repaired under warranty.
- The impeller should be rotated every three months in order to keep the seals lubricated and not develop a permanent set.

If panel is to be stored, the following is advised:

- Store the panel inside whenever possible and leave in the shipping carton.
- All openings shall be sealed.
- Store in an upright position.
- Do not stack anything on top of panel.

START-UP PROCEDURE

Before placing the equipment into operation the following should be checked:

- Correct pump rotation (3 Phase units only).
- Clean pit.
- Panel dry, securely installed and properly sealed.
- Floats positioned properly.
- Discharge valves open.
- 3/16" vent hole drilled in pipe between check valve and pump.

Once the above has been verified proceed with the following checks:

- Pump power cables properly connected to panel.
- Float cables properly connected to panel.
- Conduit connections to panel are properly sealed.
- Thermal overload adjustments made in the panel.
- After installing the pump into the containment area, with adequate submergence, open the discharge valve fully. Start the unit using manual controls. If flow is appreciably less than rated performance, pump may be air locked. To expel trapped air, jog the unit several times, using the manual controls.
- Have a qualified technician take voltage and current measurements with the pump running. Record these readings in the space provided in the "Owner's Information" section on page 1 of this manual for future reference.

After the preoperational functional test has been completed, system is ready for operation. Zoeller requires completing a Start-up Report (ZM1074) whenever a system is started for the first time or after a system has had a significant change take place (i.e. pump replacement, overhaul, etc.). A copy of the Start-up Report should remain with the system for future reference.

ADJUSTMENT PROCEDURE

Pumps: No adjustments are required other than assuring correct rotation.

Panels: The thermal overloads in the panel must be set to the F.L.A. rating on the pump nameplate (or refer to pump data sheet).

Floats: Refer to the system drawing for desired location of each float function.

Valves: Shutoff valves should be placed in the fully open position. Systems should not be operated for extended periods of time with the discharge valves partially closed due to damaging the valve.

SHUTDOWN PROCEDURES

If a system is shutdown for more than six months, the following is recommended:

Pumps: If pit is to remain dry, then the pump can remain in the pit. With the pump in the pit, it should be operated for five minutes once every three months. If the pit is to remain wet, the pump should be removed and stored as noted above.

Panels: The panel should have all openings sealed to prevent moisture and dust from entering the enclosure. Prior to restarting system, the panel should be inspected for presence of moisture and any loose connections.

Valves: Consult the valve/actuator supplier for information concerning these systems components.

MAINTENANCE

▲ NOTICE Repair and service should be performed by Zoeller Pump Company Authorized Service Station only.

SAFETY PROCEDURES

▲ WARNING For your protection, always disconnect pump and panel from its power source before handling.

▲ WARNING Never enter the basin until it has been properly vented and tested. Any person entering a basin should be wearing a harness with safety rope extending to the surface so that they can be pulled out in case of asphyxiation. Sewage water gives off methane and hydrogen sulfide gases, both of which can be highly poisonous.

Installation and checking of electrical circuits and hardware should be performed by a qualified electrician.

Pump is never to be lifted by power cord.

▲ WARNING Unit must be flushed and disinfected, inside and out, prior to servicing.

GENERAL SYSTEM INSPECTION

Before the system is placed into operation, a system Start-up Report should be completed by a qualified technician.

▲ WARNING Wiring and grounding must be in accordance with the national electrical code and all applicable local codes and ordinances.

LUBRICATION PROCEDURES

No lubrication is required.

If pumps are to be stored for more than six months, refer to short term storage procedure in the Operation section.

PREVENTIVE MAINTENANCE

Preventive maintenance will ensure a longer service life from the product. The following is a suggested maintenance schedule.

Every month:

- Check for proper and unobstructed float operation.
- Listen for proper check valve operation.
- Check and record the amp draw through the three power leads.

- If the panel has an elapsed-time meter, check operating times. Uneven times indicate a defective unit, float switch or control on a duplex system.
- Inspect the panel for any presence of moisture in enclosure, loose connections, and general component condition. Check out location and condition of float switches.

Every year:

- In addition to the monthly checks, the basin should be inspected and cleaned. Any defective components should be replaced. Inspect and remove any sand, debris, or mud present in the pump basin assembly.

Every two years:

Check insulating oil in motor and seal chambers. Inspect oil for contaminations as follows:

- Clear oil, no burnt odor - Oil, motor and seals are in satisfactory condition.
- Dark oil, burnt odor - Pump motor has overheated. Check the motor winding resistance to ground. Ohm readings of 1 megaohm or higher is required. If lower readings are present, return the unit to an Zoeller Authorized Service Station for service.
- Milky, emulsified oil - Seals have failed. Unit must be returned to an authorized service facility for service.
- Dispose of the motor insulating oil properly if replacement is required.
- Inspect power cables for damage or wear. Replace immediately if damage or wear is detected.
- Inspect impeller for damage or wear. Replace as required by a Zoeller Authorized Service Station.

DOUBLE SEAL PUMPS

- Double seal pumps offer extra protection from damage caused by seal failure.
- Oil in a motor housing and lower seal cavity must be checked when pump is serviced. If oil from the motor housing contains water or other contamination, both seals should be replaced during maintenance. Always replace with new factory recommended oil and service parts. All repairs must be made by Zoeller Authorized Service Stations.

SERVICE CHECKLIST & TROUBLE SHOOTING



⚠ WARNING ELECTRICAL PRECAUTIONS Before servicing a pump, always shut off the main power breaker to the panel and then disconnect the pump - making sure you are wearing insulated protective sole shoes and are not standing in water. Under flooded conditions, contact your local electric company or a qualified licensed electrician for disconnecting electrical service prior to pump removal.

⚠ WARNING Submersible pumps contain oils which become pressurized and hot under operating conditions - **allow 2-1/2 hours after disconnecting before attempting service.**

CONDITION

A. Pump will not start or run.

Steps	Check Voltage At	If No Voltage	If Voltage
No. 1	Line terminals in pump's control panel L1 - L2 - L3 (3 Phase)	Check Disconnect switch, line fuse, and/or circuit breakers in power supply circuit.	Proceed to No. 2
No. 2	Pump motor terminals in pump's control panel T1 - T2 - T3	Check for control circuit voltage. Check out magnetic starter contacts, thermal overloads, and float switches	Check starting relay and capacitor (1 phase units). Check pump for ground, and binding impeller

COMMON CAUSES

B. Motor overheats and trips overload or blows fuse.

- Incorrect Voltage
- Unbalanced power source
- Incorrect motor rotation
- Negative or low head
- Excessive water temperature
- Impeller, cutter, or seal mechanically bound
- Defective capacitor or relay
- Motor shorted
- Lost a leg in a Three Phase unit

C. Pumps starts and stops too often.

- Check valve stuck open
- Level controls out of adjustment
- Temperature sensor tripping
- Thermal overload switch out of adjustment or defective
- Pit too small

D. Pump will not shut off.

- Debris clogging cutter plate
- Debris under float switch
- Float travel obstructed
- Defective or damaged float switch
- Magnetic starter contacts shorted
- Air lock - check vent hole

E. Pump operates but delivers little or no water.

- Check for plugged cutter, pump housing, pipe or sticking check valve
- Vent hole clogged or not drilled
- Discharge head exceeds pumps capacity
- Low or incorrect voltage
- Incorrect motor rotation
- Defective capacitor

F. Drop in head and/or capacity after a period or use.

- Increase Pipe Friction
- Clogged line or check valve
- Abrasive material & chemical, deteriorated impeller and pump housing

If the above check list does not uncover the problem, consult the factory. Do not attempt to service or otherwise disassemble pump.