

Trusted. Tested. Tough.®

Product information presented here reflects conditions at time of publication. Consult factory regarding discrepancies or inconsistencies.



SECTION: Z5.00.120

ZM1536

1219

Supersedes

1012

MAIL TO: P.O. BOX 16347 • Louisville, KY 40256-0347
 SHIP TO: 3649 Cane Run Road • Louisville, KY 40211-1961
 (502) 778-2731 • 1 (800) 928-PUMP • FAX (502) 774-3624

Visit our website:
 zoellerengineered.com



STARTER KITS, A-PAK, J-PAK

STARTER KITS

Starter Kit P/N	Pump Model	Type
10-0380	7011 / 7012 / 7013 / X7011 / X7012 / X7013	Shipped Loose
10-0918	6111 / X6111	Shipped Loose
10-0916	6120 / 6121 / X6120 / X6121 (before 10/1/07)	Shipped Loose
10-2220	6120 / 6121 / X6120 / X6121 (after 10/1/07)	Shipped Loose
10-0917	6122 / 6123 / X6122 / X6123	Shipped Loose
10-1433	6124 / X6124	Shipped Loose
10-0458	6220	Shipped Loose
10-0459	6221	Shipped Loose
10-1011	6111 / 7110 / 7111 / X6111 / X7110 / X7111	Shipped Loose
013736	7011 / 7012 / 7013 / X7011 / X7012 / X7013	Bracket Mounted
015157	6122 / 6123 / X6122 / X6123	Bracket Mounted
015158	6124 / X6124	Bracket Mounted
015159	6111 / 7110 / 7111 / X6111 / X7110 / X7111	Bracket Mounted

A starter kit is required for all single phase heavy duty solids handling and grinder pumps.

A starter kit consist of the single phase capacitors with start relay required to run the pump.

The kit is to be field installed in the control panel. There are two types, shipped loose for field assembly or prewired and mounted on a SS bracket.

“A-PAK” ALARM SYSTEM

INDOOR/OUTDOOR ALARM SYSTEM FEATURES

Model 10-0623

- Indoor & outdoor use per UL 864
- UL Listed and CSA Certified
- Alarm system (horn & light) operates to warn of a high water condition
- Horn is rated 82 decibels at 10'
- Alarm test and horn silence switch with auto reset
- Float switch with 15' cable included
- Interior pump and float switch terminal block



“A-PAK II” ALARM SYSTEM FEATURES

Model 10-0126

- NEMA 4X thermoplastic alarm panel
- Horn & light warn of high liquid levels
- Test and silence switch
- Auxiliary dry high level alarm contacts - 5 amps
- Operates on separate circuit from pump 115V, AC
- Float switch with 20' cable included
- Can be used with liquids to 140°F (60°C)



Products may not be exactly as pictured.

“J-PAK” - WATERTIGHT JUNCTION BOXES

NEMA 4X Junction boxes are electrical enclosures that are watertight, dust-tight, and corrosion resistant.

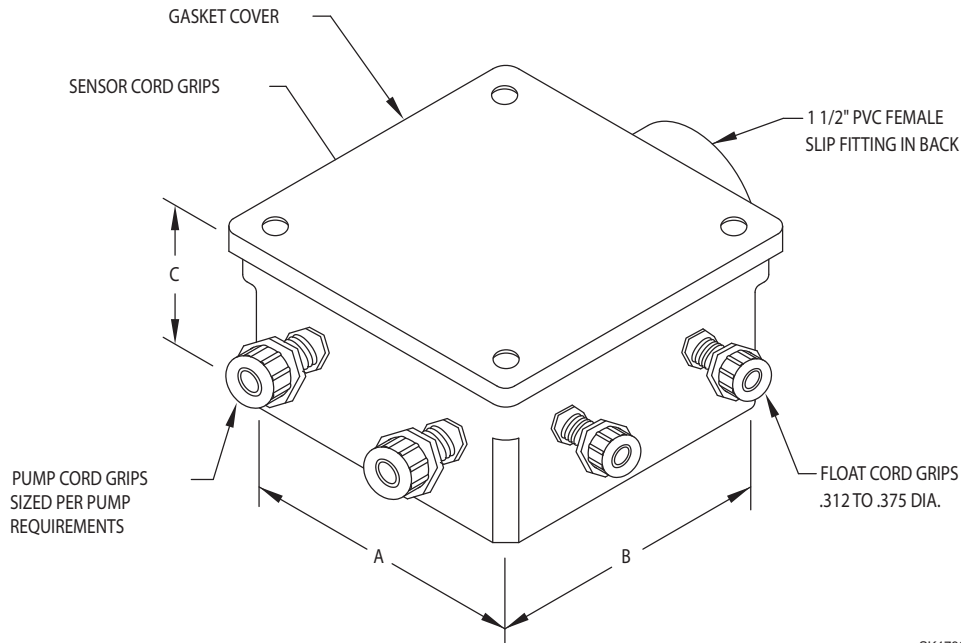

SK1739

Part No.	Pump Model	FLA (Amps)	Type	“A”	“B”	“C”	Cord Grips*
10-0647	Commercial Duty	All Models	Simplex	6"	6"	4"	1 pump / 3 float
10-1403	Commercial Duty w/ Moisture Probes	1.7 - 12 Amps	Simplex	6"	6"	4"	1 pump / 1 moisture probe 3 float
10-0985	61HD, 62HD and 71 Series	< 20 Amps	Simplex	6"	6"	4"	1 pump / 1 sensor / 3 float
10-0987	61HD, 62HD and 71 Series	20 - 36.7 Amps	Simplex	6"	6"	4"	1 pump / 1 sensor / 3 float
10-0649	Commercial Duty	All Models	Duplex	6"	6"	4"	2 pump / 4 float
10-1338	Commercial Duty w/ Moisture Probes	1.7 - 12 Amps	Duplex	8"	8"	4"	2 pump / 2 moisture probe 4 float
10-1015	61 HD Series w/o Sensor Option	< 20 Amps	Duplex	8"	8"	4"	2 pump / 4 float
10-1016	61HD Series w/o Sensor Option	> 20Amps	Duplex	8"	8"	4"	2 pump / 4 float
10-0986	61HD w/ Sensor, 62HD and 71 Series	< 20Amps	Duplex	8"	8"	4"	2 pump / 2 sensor / 4 float
10-0988	61HD w/ Sensor, 62HD and 71 Series	20 - 36.7 Amps	Duplex	8"	8"	4"	2 pump / 2 sensor / 4 float

*Each junction box is supplied with one hole plug for an unused sensor or float cord grip hole.

WARNING: Junction boxes not designed to be used with explosion proof pumps and/or intrinsically safe controls.